

API 682

4TH EDITION

Mechanical Seals



Mechanical Seals & Supply Systems for:

Oil & Gas, Refinery, Petrochemical, Fertiliser,
Chemical & Many More Applications

Selection and application recommendations according to API 682



About the Company

Sealmatic designs and manufactures mechanical seals and associated products mainly for the oil & gas, chemical, pharmaceutical, pulp & paper, power, mining and many more industrial applications. Sealmatic can help relieve stress and reduce the life cycle costs associated with the most important aspects of plant operation. Sealmatic has a longstanding tradition of providing mechanical seals and sealing services that are trusted by the industry.

Sealing Technology

With a wide range of products and services, Sealmatic has solutions for every sealing requirement – such as Pusher Seals, Standard Cartridge Seals, Elastomer Bellows Seals, Metal Bellows Seals, Engineered Seals, Split Seals, Gas-Lubricated Seals and many more. Each and every Sealmatic seal is the result of numerous steps involving extensive engineering and thus processing the same in various production steps. Our engineers at Sealmatic work with discipline and passion to maintain high standards in their respective fields. With the use of 3D modelling we ensure optimum performance of application specific seals. Sealmatic has engineered high-performance products that reliably withstand extreme environments, challenging applications and evolving legislation. No matter how strict the specification or how unique the application, we have the solutions to offer. Extremely complicated seal faces for Dry Gas Seals are manufactured under a controlled environment, deploying sophisticated machines to produce intricate profiles on the seal face.

Continuous Research & Training

To maintain our position at the forefront of technological innovation, we continuously test our new designs in real-world environments, simulated by our state-of-the-art test rigs. Sealmatic provides a wide range of training courses that cover the correct procedures for installing, operating and maintaining mechanical seals. With a combination of hands on as well as theoretical training, our employees learn about safety, performance, reliability of energy services and industrial process plants including trouble shooting and problem solving, enabling them to become experts in their fields. With the deep knowledge of over 70 subjects and intricate designs, we have built a legacy to carry forward the vision of our company.

Global Sales & Service

Our aim at Sealmatic is to ensure utmost satisfaction of our customers, where we ensure international quality and close proximity. And because our partners are globally located, we can be present in person anytime, offering engineering services whenever needed. Our customers are spread across all the continents and we are very proud to state that we have 100% retention rate, we have a satisfied base of over 1000 customers across the globe.

Environmental, Health & Safety

Sealmatic's management and employees take active participation in establishing and supporting Environmental, Health and Safety (EHS) policy and procedures. By maintaining compliance with applicable EHS laws and regulations, Sealmatic strives to ensure the health, safety, and welfare of its employees and others affected by its business operations.

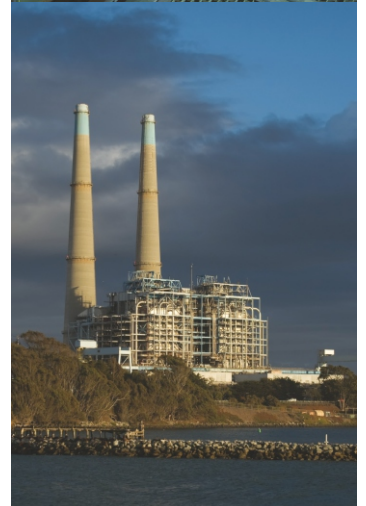

Categories, Arrangements, Configurations, Seal Types & Spring Positions

Category			Arrangement	Configuration	Seal Type	Spring Position
1	2	3				
ASME B73-1, ASME B73-2, AP 676	API 610	-40 °C ... 260 °C, 20 bar (-40 °F ... 500 °F, 290 PSI) -40 °C ... 400 °C, 40 bar (-40 °F ... 752 °F, 580 PSI)	1 Single seal cartridge • Distributed flush system	1CW-FX Contacting Wet – Fixed Throttle Bushing 1CW-FL Contacting Wet – Floating throttle bushing	A Balanced pusher seal Temperature: -40 °C ... 176 °C (-40 °F ... 350 °F) Gauge pressure: 20 bar (300 PSI) / 40 bar (600 PSI) Multiple springs: Alloy C-276 or Alloy C-4 Single spring: SS 316 O-Rings: FKM or FFKM NBR, HNBR, EPM, EPDM, TFE ... B Metal bellows seal with O-Rings Temperature: -40 °C ... 176 °C (-40 °F ... 350 °F) Gauge pressure: 20 bar (300 PSI) Metal bellows: Alloy C-276, Alloy 718 O-Rings: FKM or FFKM NBR, HNBR, EPM, EPDM, TFE ... C Metal bellows seal with flexible graphite Temperature: -40 °C ... 400 °C (-40 °F ... 750 °F) Gauge pressure: 20 bar (300 PSI) Metal bellows: Alloy 718 Secondary seal: Flexible graphite	Rotating Seal face surface speed < 23 m/s (75 ft/s) Stationary Seal face surface speed > 23 m/s (75 ft/s)
			2 Dual seal cartridge $P_{(buffer\ medium)} < P_{(seal\ chamber)}$ • Internal reverse balance feature • Distributed flush system (if possible) • Fixed carbon throttle bushing	2CW-CW Contacting Wet – Contacting Wet 2CW-CS Contacting Wet – Containment Seal (non-contacting or contacting CS) 2NC-CS Non-Contacting – Containment Seal (non-contacting or contacting CS)		Rotating Stationary
			3 Dual seal cartridge $P_{(barrier\ medium)} > P_{(seal\ chamber)}$ • Internal reverse balance feature • Fixed carbon throttle bushing • Flush connection to process side	3CW-FB Contacting Wet – Face-to-Back 3CW-BB Contacting Wet – Back-to-Back 3CW-FF Contacting Wet – Face-to-Face 3NC-BB Non-Contacting – Back-to-Back 3NC-FF Non-Contacting – Face-to-Face 3NC-FB Non-Contacting – Face-to-Back		Rotating Stationary For Arrangement 2 and Arrangement 3 the seal types can be mixed across configurations (see note of 4.1.3)
Minimal data requirements	Rigorous data requirements				ES Totally engineered sealing system Temperature: < -40 °C or > 260 °C (< -40 °F or > 500 °F) (Category 1) < -40 °C or > 400 °C (< -40 °F or > 750 °F) (Category 2/3) Gauge pressure: > 20 bar (300 PSI) (Category 1) > 40 bar (600 PSI) (Category 2/3) Surface speed: > 23 m/s (75 ft/s) Shaft diameter: < 20 (0.75 inch) or > 110 mm (4.3 inch)	Media: Highly corrosive fluids for which the specified materials are not suitable, fluids with absolute vapor pressures > 34 bar (493 PSI), unstable liquid properties (e.g. multiphase, non-Newtonian), high viscosity or pour point above or within 20 °C (36 °F) of minimum ambient temperature.

Default configuration
 Optional configuration
 Optional design feature

Seal Coding System

Mechanical seal			Design options				Size	Plans						
Category	Arrangement	Type	Containment Device		Secondary Seal Material		Face Material		Shaft Size	Piping Plan				
1	1	A	P	Plain gland for Arrangement 2 and 3	F	FKM	M	Carbon vs Nickel Bound Tungsten Carbide	Three digits, rounded up to the next whole millimeter Example 45.00 mm: 045 47.25 mm: 048 48.63 mm: 048 XXX: Unspecified	Listed in numerical order, separated by a forward slash				
2	2	B	L	Floating throttle bushing for Arrangement 1, Category 1, 2, 3	G	PTFE	N	Carbon vs Reaction Bonded Silicon Carbide						
3	3	C	F	Fixed throttle bushing for Arrangement 1, Category 1	H	Nitrile	O	Reaction Bonded Silicon Carbide vs Nickel Bound Tungsten Carbide		Process Side Between seals Atmospheric side	01	51	61	99
			C	Containment seal for 2CW-CS, 2NC-CS	I	FFKM	P	Reaction Bonded Silicon Carbide vs Reaction Bonded Silicon Carbide			02	52	62	
			S	Floating, segmented carbon bushing may be specified for Category 1, 2, 3	R	Flexible graphite	Q	Sintered Silicon Carbide vs sintered silicon carbide			03	53A	65A	
			X	Unspecified	X	Unspecified	R	Carbon vs Sintered Silicon Carbide			11	53B	65B	
				Dual seal with different secondary seal materials at the inner and outer position: Inner material/Outer material e.g. I/F			S	Graphite loaded, Reaction Bonded Silicon Carbide vs Reaction Bonded Silicon Carbide			12	53C	66A	
						T	Graphite loaded, Sintered Silicon Carbide vs Sintered Silicon Carbide				13	54	66B	
						X	Unspecified				14	55		
											21	71		
									22	72				
									23	74				
									31	75				
									32	76				
									41	72				

Example

Mechanical Seal			Design Options			Size	Plans
Category	Arrangement	Type	Containment Device	Secondary Seal Material	Face Material	Shaft Size	Piping Plan
2	2	A	P: Plain gland	I: FFKM (Inner position) F: FKM (Outer position)	N: Carbon vs Reaction Bonded Silicon Carbide	050	02/52

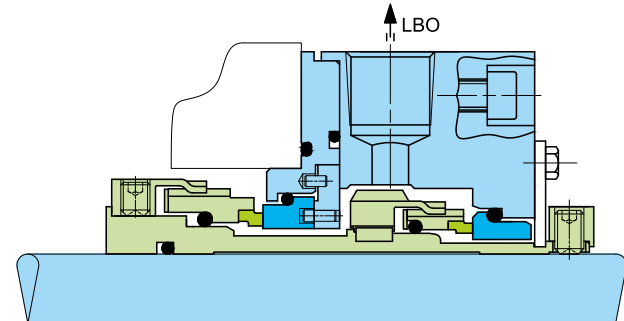

Seal designation: 22A-PI/FN-050-02/52

API 682 4th Edition Solutions At A Glance

Sealmatic Product Locator For Mechanical Seals And Seal Supply Systems.

Category			Category 1								
Configuration			1CW-FX	2CW-CW	2NC-CS	3CW-FB	3NC-BB				
Mechanical Seal	Seal Type A	Rotating	CTX-API-SN	CTX-API-DN	GSPH-Ta	CTX-API-DN	GSPH-KD				
		Stationary									
Category		Category 2 and 3									
Configuration		1CW-FL	2CW-CW	2CW-CS	2NC-CS	3CW-FB	3CW-BB	3CW-FF	3NC-FB	3NC-BB	3NC-FF
Mechanical Seal	Seal Type A	Rotating	B750VN	B750VK	B750VK-GSPH	GSPH-Ta	B750VK	B750VK-D		GSPH-KD	
		Stationary	SB	SB-Ta			SB-Ta		SB-D	BGSR-Ta	GSR-D
	Seal Type B	Rotating	UFL850	UFL850-Ta			UFL850-Ta	UFL850-D			
		Stationary									
		Rotating	UFLWT800	UFLWT800-Ta			UFLWT800-Ta	UFLWT800-D			
Seal Type C	Stationary	UFL650	UFL650-Ta			UFL650-Ta		UFL650-D			

CTXAPI-SN

API 682 4th Edition Category 1
 Seal Type A (Rotating)
 Configuration 1CW-FX (Contacting Wet – Fixed throttle bushing)

Product Description

1. API 682 Category 1, Type A, Arrangement 1
2. Single seal configuration
3. Balanced design
4. Independent of direction of rotation
5. Cartridge construction
6. Robust construction with shrink-fitted seal face
7. Heavy duty solid seat design

Technical Features

1. Designed to accommodate shaft deflections and process fluctuations
2. Efficient construction for heat dissipation
3. Compact installation design
4. Factory assembled cartridge unit for easy installation
5. Springs are product protected to avoid contamination
6. Can accommodate reverse pressure
7. Can handle extensive applications in various temperatures and pressures
8. Versatile in design to fit various seal chambers

Typical Industrial Applications

- Chemical industry
- Petrochemical industry
- Oil and gas industry
- Highly volatile hydrocarbons
- Toxic and hazardous media
- Media with poor lubrication properties
- Low solids content and low abrasive media
- Vertical and horizontal ANSI chemical standard pumps

Performance Capabilities

Shaft diameter: $d_1 = 20 \dots 110 \text{ mm}$ (0.79" ... 4.33")
 Pressure: $p_1 = 22 \text{ bar}$ (319 PSI)
 Temperature: $t = -40 \text{ }^\circ\text{C} \dots +176 \text{ }^\circ\text{C}$ (-40 °F ... +349 °F)
 (>176 °C (349 °F) please enquire)
 Sliding velocity: $v_g = 23 \text{ m/s}$ (75 ft/s)

Materials

Seal ring: Blister resistant carbon, Silicon carbide SSiC (Q12)
 Mating ring: Silicon carbide SSiC (Q1)
 Secondary seals: EPDM (E), NBR (P), FKM (V), FFKM (K)
 Springs: Hastelloy® C-4 (M)* and C-276 (M5)
 Metal parts: CrNiMo steel 316 (G) or equivalent, optional materials on request.
 * Sealmatic standard

Recommended piping plans

Process side: 01, 02, 03, 11, 12, 13, 14, 21, 22, 23, 31, 41, 32
 Atmospheric side: 51, 61, 62, 65A, 65B, 66A, 66B

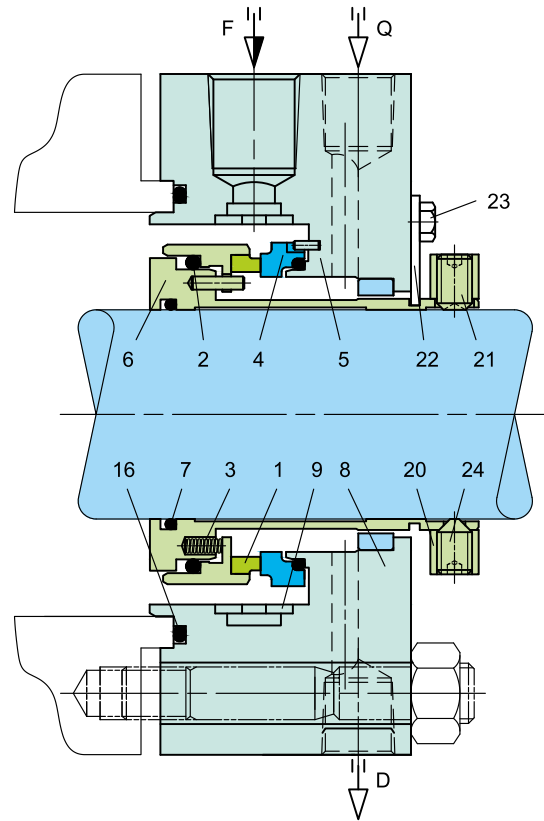

Item	Description
1	Seal ring
2, 5, 7, 16	O-ring
3	Spring
4	Mating ring
6	Shaft sleeve
8	Gland
9	Multi-flow distributor
20	Set ring
21, 24	Set screw
22	Setting plate
23	HSH cap screw
F	Flush
Q	Quench
D	Drain

CTXAPI-DN

API 682 4th Edition Category 1
 Seal Type A (Rotating)
 Configuration 2CW-CW (Contacting Wet – Contacting Wet)
 Configuration 3CW-FB (Contacting Wet – Face-to-Back)

Product Description

1. API 682 Category 1, Type A, Arrangement 2 & 3
2. Dual seal in face-to-back configuration
3. Balanced design
4. Independent of direction of rotation
5. Cartridge construction
6. Robust construction with shrink-fitted seal faces
7. Heavy duty solid seat design

Technical Features

1. Designed to accommodate shaft deflections and process fluctuations
2. Efficient construction for heat dissipation
3. Compact installation design
4. Factory assembled cartridge unit for easy installation
5. Springs are product protected to avoid contamination
6. Can accommodate reverse pressure
7. Can handle extensive applications in various temperatures and pressures
8. Versatile in design to fit various seal chambers

Typical Industrial Applications

- Chemical industry
- Light volatile and highly viscous hydrocarbons
- Low solids content and low abrasive media
- Media with poor lubrication properties
- Oil and gas industry
- Petrochemical industry
- Toxic and hazardous media
- Standard pumps
- Vertical and horizontal ANSI chemical pumps

Performance Capabilities

Shaft diameter: $d_1 = 20 \dots 110 \text{ mm}$ (0.79" ... 4.33")
 Pressure: $p_1 = 22 \text{ bar}$ (319 PSI)
 Temperature: $t = -40 \text{ }^\circ\text{C} \dots +176 \text{ }^\circ\text{C}$ (-40 °F ... +349 °F)
 (>176 °C (349 °F) please enquire)
 Sliding velocity: $v_g = 23 \text{ m/s}$ (75 ft/s)

Materials

Seal rings: Blister resistant carbon, Silicon carbide SSiC (Q12)
 Mating rings: Silicon carbide SSiC (Q1)
 Secondary seals: EPDM (E), NBR (P), FKM (V), FFKM (K)
 Springs: Hastelloy® C-4 (M)* and C-276 (M5)
 Metal parts: CrNiMo steel 316 (G) or equivalent, optional materials on request.
 * Sealmatic standard

Recommended piping plans – 2CW-CW

01, 02, 03, 11, 12, 13, 14, 21, 22, 23, 31, 41, 32
 Between seals: 52, 55
 Atmospheric side*: 61, 62, 65A, 65B
 * Depending on application, please enquire

Recommended piping plans – 3CW-FB

Process side:
 01, 02, 03, 11, 12, 13, 14, 21, 22, 23, 31, 41, 32
 Between seals: 53A, 53B, 53C, 54
 Atmospheric side*: 61, 62, 65A, 65B
 * Depending on application, please enquire

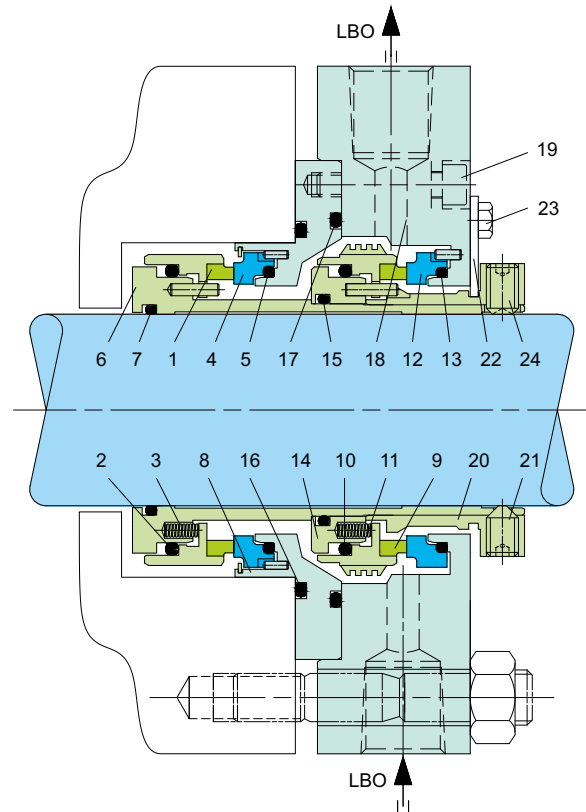

Item	Description
1, 9	Seal ring
2, 5, 7, 10, 13, 15, 16, 17	O-ring
3, 11	Spring
4, 12	Mating ring
6	Shaft sleeve
8	Intermediate Gland
14	Driver
19	HSH Cap screw
18	Gland
20	Set ring
21, 24	Set screw
22	Setting plate
23	Hexagon bolt
LBI	Liquid Buffer IN
LBO	Liquid Buffer OUT

B750VN

API 682 4th Edition Category 2 & 3
 Seal type A (Rotating)
 Configuration 1CW-FL (Contacting Wet – Floating throttle bushing)

Product Description

1. API 682 Category 2 and 3, Type A, Arrangement 1
2. Single seal configuration
3. Balanced design
4. Independent of direction of rotation
5. Cartridge construction
6. Pumping device available for increased efficiency in circulation
7. Rotary unit with multiple springs

Technical Features

1. Robust and compact design
2. Standardised components allows efficient stock-keeping
3. Extensive applications in the field covering varied temperatures and pressures
4. Extensive selection of materials
5. Metal parts available in special materials
6. Universally applicable both for retrofits or original equipments

Typical Industrial Applications

- API 610/ISO 13709 pumps
- Oil and gas industry
- Refining technology
- Petrochemical industry
- Chemical industry
- Highly volatile hydrocarbons
- LPG plants
- Power plant technology
- Process pumps

Performance Capabilities

Shaft diameter: $d = 20 \dots 110 \text{ mm}$ (0.79" ... 4.33")
 Pressure: $p_1 = \dots 42 \text{ bar}$ (609 PSI)
 Temperature: $t = -40 \text{ }^\circ\text{C} \dots +176 \text{ }^\circ\text{C}$ (-40 °F ... +349 °F)*
 Sliding velocity: $v_g = 23 \text{ m/s}$ (75 ft/s)
 Axial movement:
 $d \leq 40 \text{ mm} \pm 1.0 \text{ mm}$
 $d \geq 40 \text{ mm} \pm 1.5 \text{ mm}$
 * Engineered up to 260 °C (500 °F) with FFKM (K) secondary seals

Materials

Seal ring: Blister resistant carbon, Silicon carbide SSiC (Q1), RBSiC (Q2)
 Mating ring: Silicon carbide SSiC (Q1), RBSiC (Q2)
 Secondary seals: EPDM (E), NBR (P), FKM (V), FFKM (K)
 Springs: Hastelloy® C-276 (M5)
 Metal parts: CrNiMo steel 316 (G) or equivalent, optional materials on request.

Recommended piping plans

Process side:
 01, 02, 03, 11, 12, 13, 14, 21, 22, 23, 31, 32, 41
 Atmospheric side: 51, 61, 62, 65A, 65B, 66A, 66B

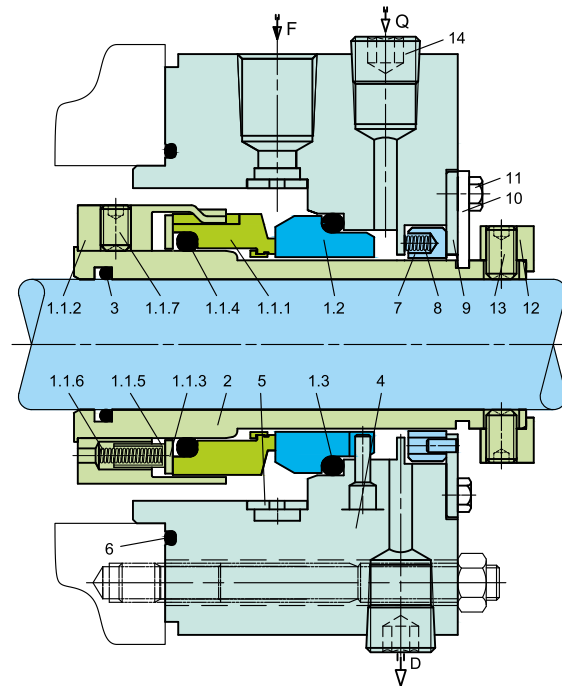

Item	Description
1.1.1	Seal ring
1.1.2	Driver
1.1.3	Thrust ring
1.1.4, 1.3, 3, 6	O-ring
1.1.5	Spring Sleeve
1.1.6, 8	Spring
1.1.7, 13	Set screw
1.2	Mating ring
2	Shaft sleeve
4	Gland
5	Multi-flow distributor
7	Throttle bushing
9	Washer
10	Setting plate
11	Hexagon bolt
12	Set ring
14	Plug
F	Flush
Q	Quench
D	Drain

B750VK

API 682 4th Edition Category 2/3
 Seal type A (Rotating)
 Configuration 2CW-CW (Contacting Wet – Contacting Wet)
 Configuration 3CW-FB (Contacting Wet – Face-to-Back)

Product Description

1. API 682 Category 2 and 3, Type A, Arrangement 2 & 3 seal
2. Dual seal in face-to-back configuration
3. Balanced design
4. Independent of direction of rotation
5. Cartridge construction
6. Pumping device available for increased efficiency in circulation
7. Rotary unit with multiple springs
8. Can accommodate reverse pressure

Technical Features

1. Can handle extensive applications in various temperatures and pressures
2. Versatile in design to fit various seal chambers
3. Material of construction available in special metallurgy
4. Special torque transmission design for high performance
5. Operation reliability due to rugged metal torque transmission at the rotating seal face

Typical Industrial Applications

- API 610/ISO 13709 pumps
- Oil and gas industry
- Refining technology
- Petrochemical industry
- Chemical industry
- Highly volatile hydrocarbons
- LPG plants
- Power plant technology
- Process pumps

Performance Capabilities

Shaft diameter: $d = 20 \dots 110 \text{ mm}$ (0.79" ... 4.33")
 Pressure: $p_1 = \dots 42 \text{ bar}$ (609 PSI)
 Temperature: $t = -40 \text{ }^\circ\text{C} \dots +176 \text{ }^\circ\text{C}$ (+220 °C)
 (-40 °F ... +349 °F (+428 °F))*
 Sliding velocity: $v_g = 23 \text{ m/s}$ (76 ft/s)
 Axial movement:
 $d \leq 40 \text{ mm} \pm 1.0 \text{ mm}$
 $d > 40 \text{ mm} \pm 1.5 \text{ mm}$
 * Engineered up to 260 °C (500 °F) with FFKM (K) secondary seals

Materials

Seal rings: Blister resistant carbon, Silicon carbide SSiC (Q1), RBSiC (Q2)
 Mating rings: Silicon carbide SSiC (Q1), RBSiC (Q2)
 Secondary seals: EPDM (E), NBR (P), FKM (V), FFKM (K)
 Springs: Hastelloy® C-276 (M5)
 Metal parts: CrNiMo steel 316 (G), Duplex (G1), Hastelloy C-276 (M5)

Recommended piping plans 2CW-CW

Process side:
 01, 02, 03, 11, 12, 13, 14, 21, 22, 23, 31, 32, 41
 Between seals: 52, 55
 Atmospheric side: 61, 62, 65A, 65B

Recommended piping plans 3CW-FB

Process side:
 01, 02, 03, 11, 12, 13, 14, 21, 22, 23, 31, 32, 41
 Between seals: 53A, 53B, 53C, 54
 Atmospheric side: 61, 62, 65A, 65B

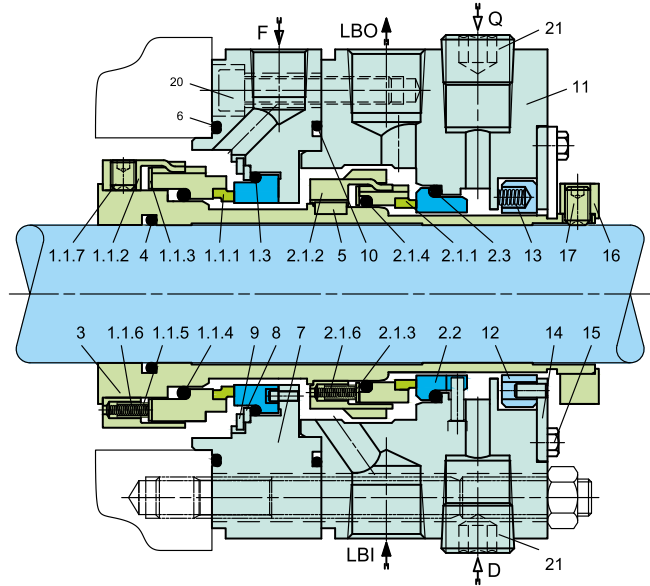

Item	Description
1.1.1, 2.1.1	Seal ring
1.1.2, 2.1.2	Driver
1.1.3, 2.1.3	Thrust ring
1.1.4, 1.3, 2.1.4, 2.3, 4, 6, 10	O-ring
1.1.5, 2.1.5	Spring sleeve
1.1.6, 2.1.6, 13	Spring
1.1.7, 17	Set screw
1.2, 2.2	Mating ring
3	Shaft sleeve
5	Key
7	Intermediate gland
8, 14	Washer
9	Retaining ring
11	Gland
12	Throttle bushing
15, 19	Hexagonal screw
16	Set ring
18	Setting Plate
20	HSH cap screw
21	Head screw plug
F	Flush
LBI	Liquid Buffer/Barrier IN
LBO	Liquid Buffer/Barrier OUT
Q	Quench
D	Drain

B750VK-D

API 682 4th Edition Category 2 & 3
 Seal type A (Rotating)
 Configuration 3CW-BB (Contacting Wet – Back-to-Back)

Product Description

1. API 682 Category 2 and 3, Type A, Arrangement 3 seal
2. Dual seal in back-to-back configuration
3. Balanced design
4. Independent of direction of rotation
5. Cartridge construction
6. Pumping device available for increased efficiency in circulation
7. Rotary unit with multiple springs
8. Can accommodate reverse pressure

Technical Features

1. Can handle extensive applications in various temperatures and pressures
2. Versatile in design to fit various seal chambers
3. Material of construction available in special metallurgy
4. Special torque transmission design for high performance
5. Operation reliability due to rugged metal torque transmission at the rotating seal face

Typical Industrial Applications

- API 610/ISO 13709 pumps
- Oil and gas industry
- Refining technology
- Petrochemical industry
- Chemical industry
- Highly volatile hydrocarbons
- LPG plants
- Power plant technology
- Process pumps

Performance Capabilities

Shaft diameter: $d = 20 \dots 110 \text{ mm} (0.79" \dots 4.33")$

Pressure: $p_1 = \dots 42 \text{ bar} (609 \text{ PSI})$

Temperature: $t = -40 \text{ }^\circ\text{C} \dots +176 \text{ }^\circ\text{C}$
 $(-40 \text{ }^\circ\text{F} \dots +350 \text{ }^\circ\text{F})^*$

Sliding velocity: $v_g = 23 \text{ m/s} (76 \text{ ft/s})$

Axial movement: $d \leq 40 \text{ mm} \pm 1.0 \text{ mm}$, $d > 40 \text{ mm} \pm 1.5 \text{ mm}$

* Engineered up to $260 \text{ }^\circ\text{C} (500 \text{ }^\circ\text{F})$ with FFKM (K) secondary seals

Materials

Seal rings: Blister resistant carbon,

Silicon carbide SSiC (Q1), RBSiC (Q2)

Mating rings: Silicon carbide SSiC (Q1), RBSiC (Q2)

Secondary seals: EPDM (E), NBR (P), FKM (V), FFKM (K)

Springs: C-276 (M5)

Metal parts: CrNiMo steel 316 (G) or equivalent, optional materials on request.

Recommended piping plans

Process side*:

01, 02, 03, 11, 12, 13, 14, 21, 22, 31, 32, 41

Between seals: 53A, 53B, 53C, 54

Atmospheric side**:

* Piping plans 11 ... 41:

Integration in seal to be dimensionally checked.

** Throttle bushing on request.

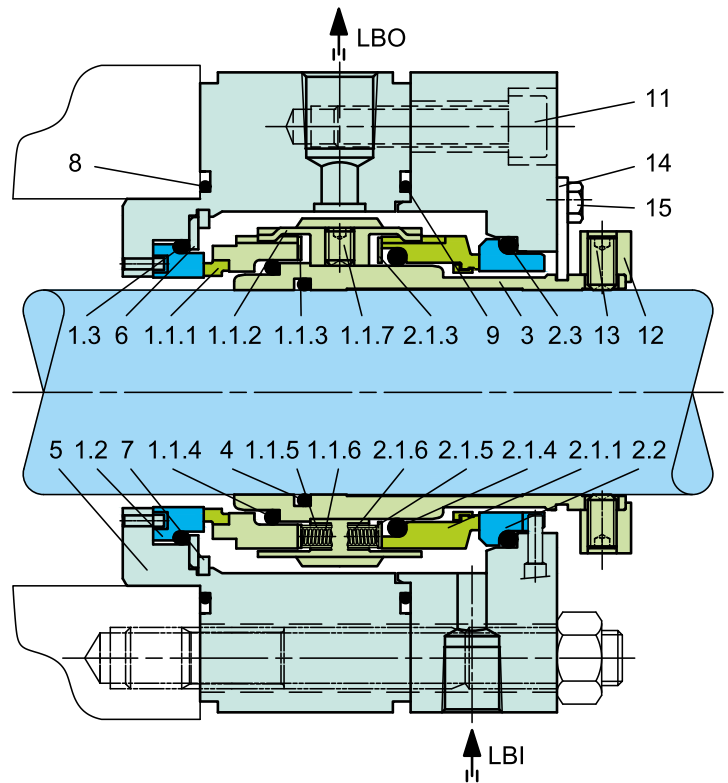

Item	Description
1.1.1, 2.1.1	Seal ring
1.1.2, 2.1.2	Driver
1.1.3, 2.1.3	Thrust ring
1.1.4, 1.3, 2.1.4, 2.3, 4, 8, 9	O-ring
1.1.5, 2.1.5,	Spring sleeve
1.1.6, 2.1.6,	Spring
1.1.7, 2.1.7	Set screw
1.2, 2.2	Mating ring
3	Shaft sleeve
5	Adapter
6	Washer
7	Retaining ring
10	Cover
11	HSH cap screw
12	Set ring
13	Set screw
14	Assembly plate
15	Hexagonal bolt
LBI	Liquid Barrier IN
LBO	Liquid Barrier OUT

Product Description

1. API 682 Category 2 and 3, Type A, Arrangement 1 seal
2. Single seal configuration
3. Balanced design
4. Independent of direction of rotation
5. Cartridge construction
6. Stationary design with multiple springs
7. Designed with integrated pumping device for increased efficiency in circulation
8. Robust construction with shrink-fitted seal face
9. Heavy duty design of solid seat

Technical Features

1. Accommodates shaft deflections due to stationary design
2. Can be designed for individual pump application with corresponding connection parts to be adopted to the pump seal chamber
3. Optimum heat dissipation due to integrated pumping device available for increased efficiency in circulation and optimized seat design
4. Cartridge unit factory assembled for easy installation, which reduces downtime
5. Trouble-free long-term operation due to heavy duty single seat design with bandage
6. Can operate under high sliding velocities and high pressures

Typical Industrial Applications

- Oil and gas industry
- Refining technology
- Chemical industry
- Hot water
- Sour water
- Caustic soda
- Amines
- Crystallizing media
- Crude oil
- Process water
- Crude oil feed pumps
- Injection pumps
- Multiphase pumps

Performance Capabilities

Shaft diameter: $d_1 = 40 \dots 110$ (250) mm
 (1.57" ... 4.33 (9.84)"
 Pressure: $p_1 = 42$ (150) bar (609 (2,175) PSI)
 Temperature: $t = -40$ °C ... $+176$ (+200) °C
 (-40 °F ... $+350$ (+394) °F)
 Sliding velocity: $v_g = 23$ (60) m/s (76 (197) ft/s)
 Axial movement: ± 3.0 mm

Materials

Seal ring: Blister resistant carbon,
 Silicon carbide SSiC (Q1), RBSiC (Q2, Q3)
 Mating ring: Silicon carbide SSiC (Q1), RBSiC (Q2)
 Secondary seals: EPDM (E), NBR (P), FKM (V), FFKM (K)
 Springs: Hastelloy® C-4 (M)* and C-276 (M5)
 Metal parts: CrNiMo steel 316 (G) or equivalent,
 optional materials on request.
 * Sealmatic standard

Recommended piping plans

Process side:
 01, 02, 03, 11, 12, 13, 14, 21, 22, 23, 31, 32, 41
 Atmospheric side: 51, 61, 62, 65A, 65B, 66A, 66B

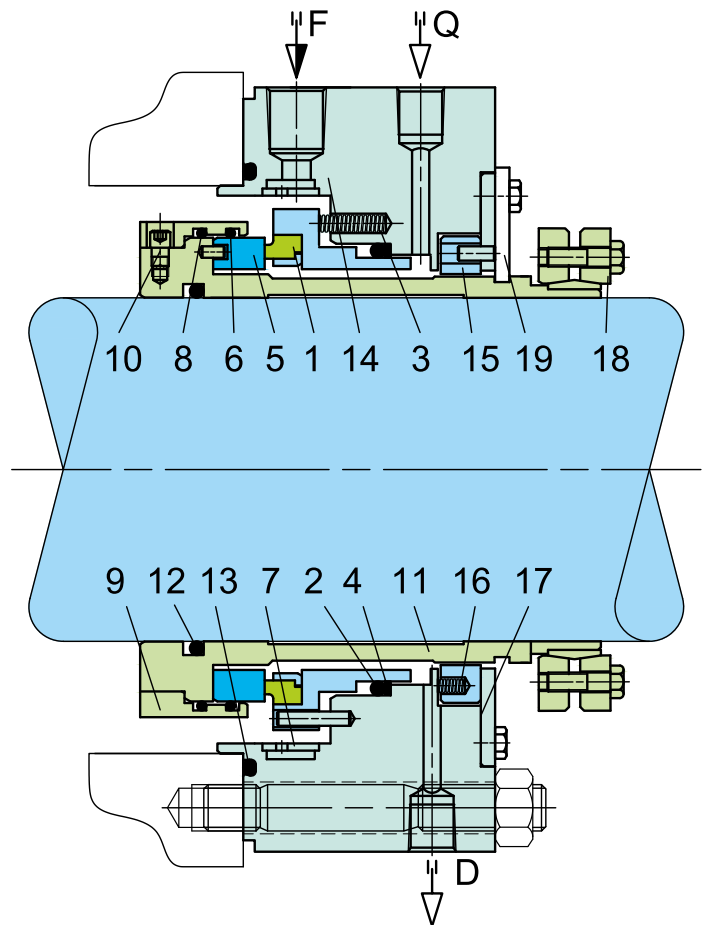

Item	Description
1	Seal ring
2, 6, 8, 12, 13	O-ring
3, 16	Spring
4	Back-up ring
5	Mating ring
7	Multi-flow distributor
9	Sleeve
10	Set screw
11	Shaft sleeve
14	Gland
15	Throttle bushing
17	Washer
18	Shrink Disc
19	Setting plate
20	Hexagon bolt
F	Flush
Q	Quench
D	Drain

SB-Ta

API 682 4th Edition Category 2 & 3
 Seal type A (Stationary)
 Configuration 2CW-CW (Contacting Wet – Contacting Wet)
 Configuration 3CW-FB (Contacting Wet – Face-to-Back)

Product Description

1. API 682 Category 2 and 3, Type A, Arrangement 2 & 3 seal
2. Dual seal in face-to-back configuration
3. Balanced design
4. Independent of direction of rotation
5. Cartridge construction
6. Stationary design with multiple springs
7. Designed with integrated pumping device for increased efficiency in circulation
8. Robust construction with shrink-fitted seal face
9. Heavy duty design of solid seat

Technical Features

1. Accommodates shaft deflections due to stationary design
2. Can be designed for individual pump application with corresponding connection parts to be adopted to the pump seal chamber
3. Optimum heat dissipation due to integrated pumping device available for increased efficiency in circulation and optimized seat design
4. Cartridge unit factory assembled for easy installation, which reduces downtime
5. Trouble-free long-term operation due to heavy duty single seat design with bandage
6. Can operate under high sliding velocities and high pressures

Typical Industrial Applications

- Multiphase pumps API 610/ISO 13709 pumps
- Oil and gas industry
- Refining technology
- Chemical industry
- Hot water
- Sour water
- Caustic soda
- Amines
- Crystallizing media
- Crude oil
- Process water
- Crude oil feed pumps
- Injection pumps

Performance Capabilities

Shaft diameter: $d_1 = 20 \dots 110 \text{ mm}$ (0.79" ... 4.33")
 Pressure: $p = 60 \text{ bar}$ (870 PSI)
 Temperature: $-40 \text{ }^\circ\text{C} \dots +176 \text{ }^\circ\text{C}$ ($-40 \text{ }^\circ\text{F} \dots +349 \text{ }^\circ\text{F}$)*
 Sliding velocity: $v_g = 50 \text{ m/s}$ (164 ft/s)
 * Engineered up to $260 \text{ }^\circ\text{C}$ ($500 \text{ }^\circ\text{F}$) with FFKM (K) secondary seals

Materials

Seal rings: Blister resistant carbon, Silicon carbide SSiC (Q1), RBSiC (Q2)
 Mating rings: Silicon carbide SSiC (Q1), RBSiC (Q2)
 Secondary seals: FKM (V), FFKM (K), EPDM (E), NBR (P)
 Springs: Hastelloy® C-276 (M5)
 Metal parts: CrNiMo steel 316 (G)

Recommended piping plans 2CW-CW

Process side:
 01, 02, 03, 11, 12, 13, 14, 21, 22, 23, 31, 32, 41
 Between seals: 52, 55
 Atmospheric side*: 61, 62, 65A, 65B
 * Throttle bushing on request

Recommended piping plans 3CW-FB

Process side:
 01, 02, 03, 11, 12, 13, 14, 21, 22, 23, 31, 32, 41
 Between seals: 53A, 53B, 53C, 54
 Atmospheric side*: 61, 62, 65A, 65B
 * Throttle bushing on request

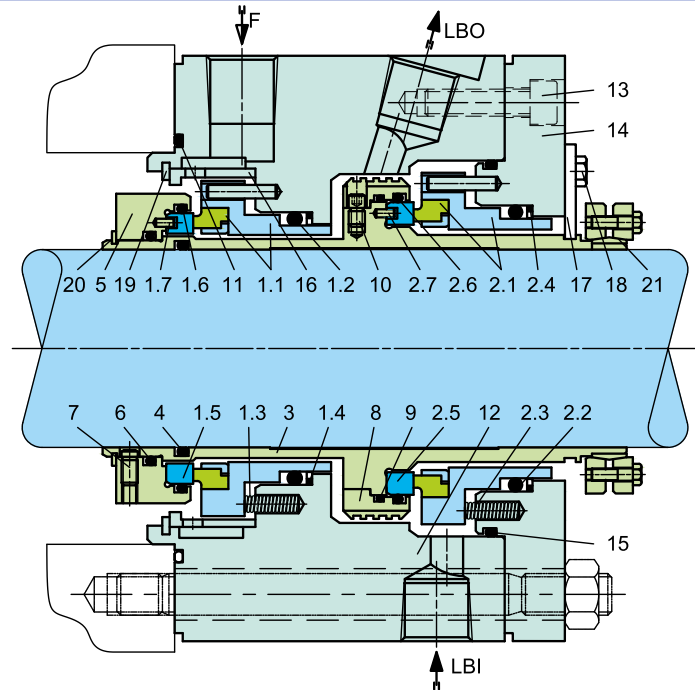

Item	Description
1.1, 2.1	Seal ring
1.2, 1.6, 2.2, 2.6, 4, 6, 9, 11, 15	O-ring
1.3, 2.3	Spring
1.4, 2.4	Back up ring
1.5, 2.5	Mating Ring
1.7, 2.7, 10	Pin
3	Shaft sleeve
5	Seat housing
7	Set screw
8	Pumping ring
12	Gland
13	HSH cap screw
14	Cover
16	Multi-flow distributor
17	Setting Plate
18	Hexagon screw
19, 20	Retaining ring
21	Shrink disc
F	Flush
LBI	Liquid Buffer/Barrier IN
LBO	Liquid Buffer/Barrier OUT

SB-D

API 682 4th Edition Category 2 & 3
 Seal type A (Stationary)
 Configuration 3CW-FF (Contacting Wet – Face-to-Face)

Product Description

1. API 682 Category 2 and 3, Type A, Arrangement 3 seal
2. Dual seal in face-to-face configuration
3. Balanced design
4. Independent of direction of rotation
5. Cartridge construction
6. Stationary design with multiple springs
7. Designed with integrated pumping device for increased efficiency in circulation
8. Robust construction with shrink-fitted seal face
9. Heavy duty design of solid seat

Technical Features

1. Accommodates shaft deflections due to stationary design
2. Can be designed for individual pump application with corresponding connection parts to be adopted to the pump seal chamber
3. Optimum heat dissipation due to integrated pumping device available for increased efficiency in circulation and optimized seat design
4. Cartridge unit factory assembled for easy installation, which reduces downtime
5. Trouble-free long-term operation due to heavy duty single seat design with bandage
6. Can operate under high sliding velocities and high pressures

Typical Industrial Applications

- Multiphase pumps API 610/ISO 13709 pumps
- Oil and gas industry
- Refining technology
- Chemical industry
- Hot water
- Sour water
- Caustic soda
- Amines
- Crystallizing media
- Crude oil
- Process water
- Crude oil feed pumps
- Injection pumps

Performance Capabilities

Shaft diameter: $d_1 = 40 \dots 110$ (250) mm
 (1.57" ... 4.33 (9.84)"

Pressure: $p_1 = 42$ (150) bar (609 (2,175) PSI)

Temperature: $t = -40$ °C ... +176 (+200) °C (-40 °F ... +350 (+394) °F)

Sliding velocity: $v_g = 23$ (60) m/s (76 (197) ft/s)

Axial movement: ± 3.0 mm

Materials

Seal rings: Blister resistant carbon,

Silicon carbide SSiC (Q1), RBSiC (Q2, Q3)

Mating rings: Silicon carbide SSiC (Q1), RBSiC (Q2)

Secondary seals: EPDM (E), NBR (P), FKM (V), FFKM (K)

Springs: Hastelloy® C-4 (M)* and C-276 (M5)

Metal parts: CrNiMo steel 316 (G) or equivalent, optional materials on request.

* Sealmatic standard

Recommended piping plans

Process side*: 01, 02, 03, 11, 12, 13, 14, 21, 22, 31, 32, 41

Between seals: 53A, 53B, 53C, 54

Atmospheric side**: 61, 62, 65A, 65B

* Piping plans 11 ... 41:

Integration in seal to be dimensionally checked.

** Throttle bushing on request.

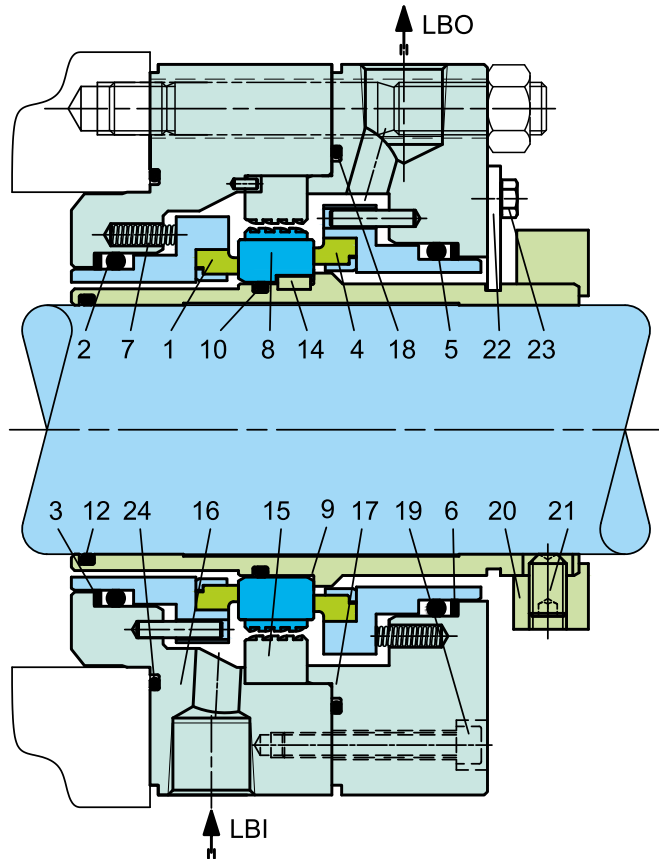

Item	Description
1, 4	Seal ring
2, 5, 10, 12, 18, 24	O-ring
3, 6,	Back up ring
7	Spring
8	Mating ring
9	Shaft sleeve
14	Key
15	Pumping sleeve
16	Adapter
17	Cover
19	HSH cap screw
20	Set ring
21	Set screw
22	Assembly fixture
23	Hexagon bolt
LBI	Liquid Barrier IN
LBO	Liquid Barrier OUT

UFL850

API 682 4th Edition Category 2 & 3
 Seal type B (Rotating)
 Configuration 1CW-FL (Contacting Wet – Floating throttle bushing)

Product Description

1. API 682 Category 2 and 3, Type B, Arrangement 1 seal
2. Single seal configuration
3. Balanced design
4. Independent of direction of rotation
5. Cartridge Construction
6. For plain shafts
7. Rotary metal bellows design
8. Shrink fitted seal ring and solid stationary ring

Technical Features

1. Compact design construction
2. Balanced bellows design allows installation on plain sleeve
3. Elimination of seal face hang up due to absence of dynamic O-Ring
4. Face load variation is minimised due to bellows design on account of shaft expansion or face wear
5. Resistance to abrasive particles in the medium, no shaft or sleeve fretting
6. Narrow seal face width leads to low heat generation and power consumption
7. Extended seal life

Typical Industrial Applications

- API 610/ISO 13709 pumps
- Refining technology
- Oil and gas industry
- Petrochemical industry
- Chemical industry
- Power plant technology
- LPG plants
- Process pumps

Performance Capabilities

Shaft diameter: $d_1 = 20 \dots 110 \text{ mm}$ (0.79" ... 4.33")
 Pressure: $p = \text{vacuum} \dots 20 \text{ bar}$ (290 PSI)
 Temperature: $t = -40 \text{ }^\circ\text{C} \dots +200 \text{ }^\circ\text{C}$ (-40 °F ... +392 °F)
 Sliding velocity: $v_g \dots 23 \text{ m/s}$ (75 ft/s)

Materials

Seal ring: Blister resistant carbon
 Mating ring: Silicon carbide SSiC (Q1), RBSiC (Q2)
 Bellows: Hastelloy® C-276 (M5),
 option: Inconel® 718 (M6)
 Secondary seals: EPDM (E), NBR (P), FKM (V), FFKM (K)
 Metal parts: CrNiMo steel 316 (G), Hastelloy® C-276 (M5)

Recommended piping plans

Process side:
 01, 02, 03, 11, 12, 13, 14, 21, 22, 23, 31, 32, 41
 Atmospheric side: 51, 61, 62, 65A, 65B, 66A, 66B

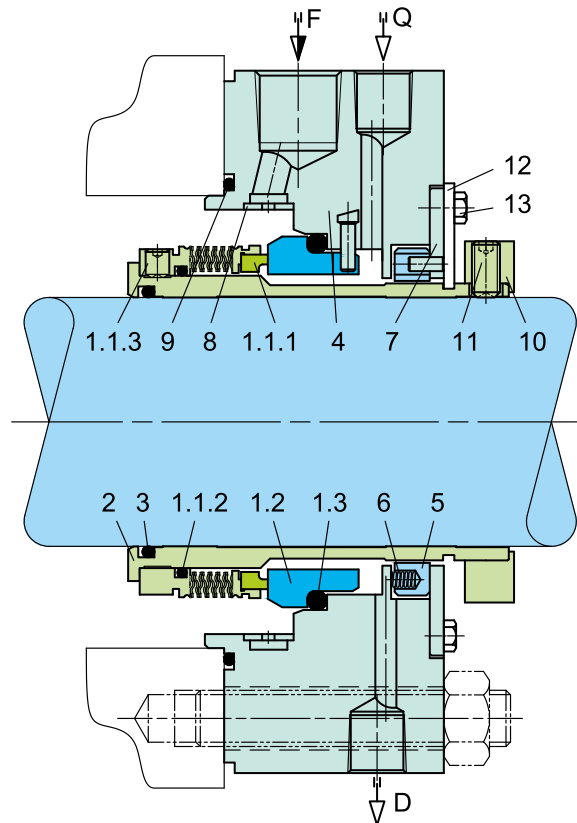

Item	Description
1.1.1	Seal Ring with Bellows Unit
1.1.2, 1.3, 3, 9	O-ring
1.1.3, 11	Set screw
1.2	Mating ring
2	Shaft sleeve
4	Gland
5	Throttle bushing
6	Spring
7	Washer
8	Multi-flow distributor
10	Set ring
12	Setting plate
13	Hexagon bolt
F	Flush
Q	Quench
D	Drain

UFLWT800

API 682 4th Edition Category 2 & 3
 Seal type C (Rotating)
 Configuration 1CW-FL (Contacting Wet – Floating throttle bushing)

Product Description

1. API 682 Category 2 and 3, Type C, Arrangement 1 seal
2. Single seal configuration
3. Balanced design
4. Independent of direction of rotation
5. Cartridge Construction
6. For plain shafts
7. Rotary metal bellows design
8. Shrink fitted seal ring and solid stationary ring

Technical Features

1. Compact construction
2. Balanced bellows design allows installation on plain sleeve
3. Elimination of seal face hang up due to absence of dynamic O-Ring
4. Face load variation is minimised due to bellows design on account of shaft expansion or face wear
5. Resistance to abrasive particles in the medium, no shaft or sleeve fretting
6. Narrow seal face width leads to low heat generation and power consumption
7. Extended seal life

Typical Industrial Applications

- API 610/ISO 13709 pumps
- Refining technology
- Oil and gas industry
- Petrochemical industry
- Chemical industry
- Power plant technology
- LPG plants
- Process pumps

Performance Capabilities

Shaft diameter: $d_1 = 20 \dots 110 \text{ mm}$ (0.79" ... 4.33")
 Pressure: $p = \text{vacuum} \dots 25 \text{ bar}$ (... 363 PSI)
 Temperature: $t = -75 \text{ }^\circ\text{C} \dots +400 \text{ }^\circ\text{C}$ (-103 °F ... +752 °F)
 Sliding velocity: $v_g \dots 23 \text{ m/s}$ (... 75 ft/s)

Materials

Seal ring: Blister resistant carbon, Silicon carbide SSiC (Q1), RBSiC (Q2)
 Mating ring: Silicon carbide SSiC (Q1), RBSiC (Q2)
 Bellows: Inconel® 718 (M6)
 Secondary seals: Graphite (G)
 Metal parts: CrNiMo steel 316 (G), Carpenter® 42 (T4)

Recommended piping plans

Process side:
 01, 02, 03, 11, 12, 13, 14, 21, 22, 23, 31, 32, 41
 Atmospheric side: 51, 61, 62, 65A, 65B, 66A, 66B

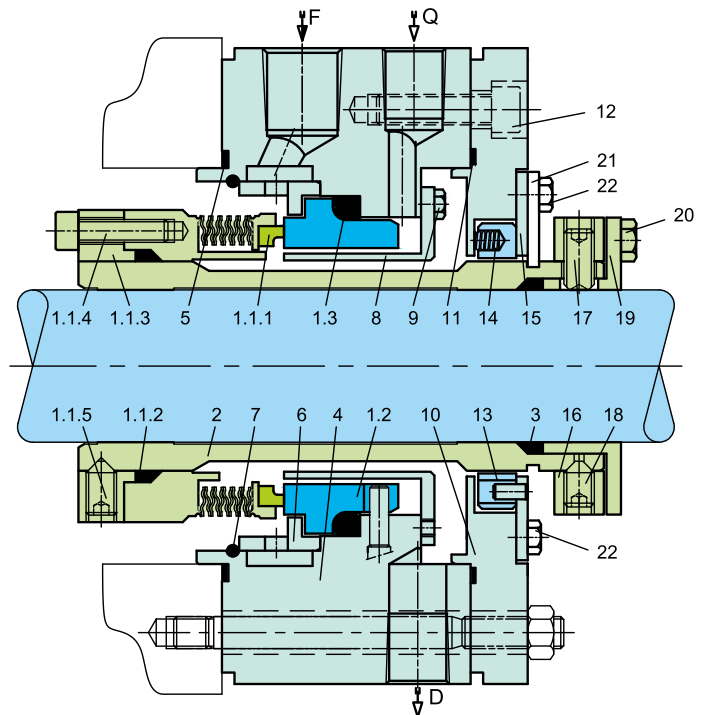

Item	Description
1.1.1	Seal ring with Bellows Unit
1.1.2, 1.3, 3	Sealing ring
1.1.3	Thrust ring
1.1.4, 12	HSH cap screw
1.1.5, 17, 18	Set screw
1.2	Mating ring
2	Shaft sleeve
4	Gland
5, 11	Gasket
6	Multi-flow distributor
7	Retaining ring
8	Quench baffle
9, 20, 22	Hexagon bolt
10	Cover
13	Throttle bushing
14	Spring
15	Washer
16	Set ring
19	Pusher ring
21	Setting plate
F	Flush
Q	Quench
D	Drain

UFL650

API 682 4th Edition Category 2 & 3
 Seal type C (Stationary)
 Configuration 1CW-FL (Contacting Wet – Floating throttle bushing)

Product Description

1. API 682 Category 2 and 3, Type C, Arrangement 1 seal
2. Single seal configuration
3. Balanced
4. Cartridge unit
5. Stationary metal bellows
6. Shrink fitted seal ring and solid mating ring

Technical Features

1. Design construction for higher speeds
2. Design accommodates run-out, squareness or vibration of the shaft
3. Compact construction
4. Balanced bellows design allows installation on plain sleeve
5. Elimination of seal face hang up due to absence of dynamic O-Ring
6. Face load variation is minimised due to bellows design on account of shaft expansion or face wear
7. Resistance to abrasive particles in the medium, no shaft or sleeve fretting
8. Narrow seal face width leads to low heat generation and power consumption
9. Extended seal life

Typical Industrial Applications

- API 610/ISO 13709 pumps
- Refining technology
- Oil and gas industry
- Petrochemical industry
- Chemical industry
- Power plant technology
- LPG plants
- Process pumps

Performance Capabilities

Shaft diameter: $d_1 = 20 \dots 110 \text{ mm}$ (0.79" ... 4.33")
 Pressure: $p = \text{vacuum} \dots 20 \text{ bar}$ (... 290 PSI)
 Temperature: $t = -130 \text{ }^\circ\text{C} \dots +400 \text{ }^\circ\text{C}$ (-202 °F ... +752 °F)
 Sliding velocity: $v_g \dots 50 \text{ m/s}$ (... 164 ft/s)

Materials

Seal ring: Blister resistant carbon,
 Silicon carbide SSiC (Q1), RBSiC (Q2)
 Mating ring: Silicon carbide SSiC (Q1), RBSiC (Q2)
 Bellows: Inconel® 718 (M6)
 Secondary seals: Graphite (G)
 Metal parts: CrNiMo steel 316 (G), Carpenter® 42 (T4)

Recommended piping plans

Process side:
 01, 02, 03, 11, 12, 13, 14, 21, 22, 23, 31, 32, 41
 Atmospheric side: 51, 61, 62, 65A, 65B, 66A, 66B

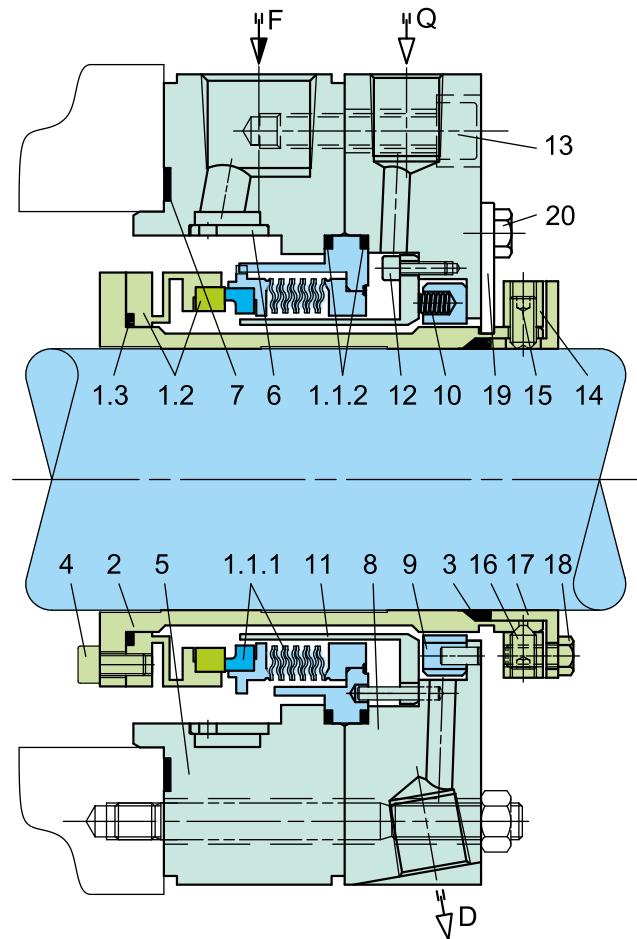

Item	Description
1.1.1	Seal ring with Bellows Unit
1.1.2, 1.3, 7	Gasket
1.2	Mating ring
2	Shaft sleeve
3	Sealing ring
4, 12, 13	HSH cap screw
5	Gland
6	Multi-flow distributor
8	Cover
9	Throttle bushing
10	Spring
11	Quench Baffle
14	Drive collar
15,16	Set screw
17	Pusher ring
18, 20	Hexagon bolt
19	Setting plate
F	Flush
Q	Quench
D	Drain

UFL850-Ta

API 682 4th Edition Category 2 & 3
 Seal type B (Rotating)
 Configuration 2CW-CW (Contacting Wet – Contacting Wet)
 Configuration 3CW-FB (Contacting Wet – Face-to-Back)

Product Description

1. API 682 Category 2 and 3, Type B, Arrangement 2 & 3 seal
2. Dual seal in face-to-back configuration
3. Balanced design
4. Independent of direction of rotation
5. Cartridge construction
6. For plain shafts
7. Rotary metal bellows design
8. Shrink fitted seal rings and solid mating rings

Technical Features

1. Suitable for high and low temperature application
2. Compact design
3. No dynamically loaded O-ring which reduces chances of seal face hang-up.
4. Pumping screw for media with higher viscosity also available
5. Short installation length possible
6. Rugged design for long operating life
7. Bellows design efficiently ensure self-cleaning
8. Bellows design minimizes variation in face load due to shaft expansion or face wear
9. Resistant to abrasive particles in the medium, no shaft or sleeve fretting

Typical Industrial Applications

- API 610/ISO 13709 pumps
- Chemical & Petrochemical industry
- Cold media
- Highly viscous media
- Hot media
- Power plant
- technology
- Refining technology
- Oil and gas industry
- Power plant technology
- LPG plants
- Process pumps

Performance Capabilities

Shaft diameter: $d_1 = 20 \dots 110 \text{ mm}$ (0.79" ... 4.33")
 Pressure: $p = \text{vacuum} \dots 20 \text{ bar}$ (290 PSI)
 Temperature: $t = -40 \text{ }^\circ\text{C} \dots +200 \text{ }^\circ\text{C}$ (-40 °F ... +392 °F)
 Sliding velocity: $v_g \dots 23 \text{ m/s}$ (75 ft/s)

Materials

Seal rings: Blister resistant carbon
 Mating rings: Silicon carbide SSiC (Q1), RBSiC (Q2)
 Bellows: Hastelloy® C-276 (M5),
 option: Inconel® 718 (M6)
 Secondary seals: FKM (V), FFKM (K), EPDM (E), NBR (P)
 Metal parts: CrNiMo steel 316 (G), Hastelloy® C-276 (M5)

Recommended piping plans 2CW-CW

Process side:
 01, 02, 03, 11, 12, 13, 14, 21, 22, 23, 31, 32, 41
 Between seals: 52, 55
 Atmospheric side*: 61, 62, 65A, 65B
 * Throttle bushing on request

Recommended piping plans 3CW-FB

Process side:
 01, 02, 03, 11, 12, 13, 14, 21, 22, 23, 31, 32, 41
 Between seals: 53A, 53B, 53C, 54
 Atmospheric side*: 61, 62, 65A, 65B
 * Throttle bushing on request

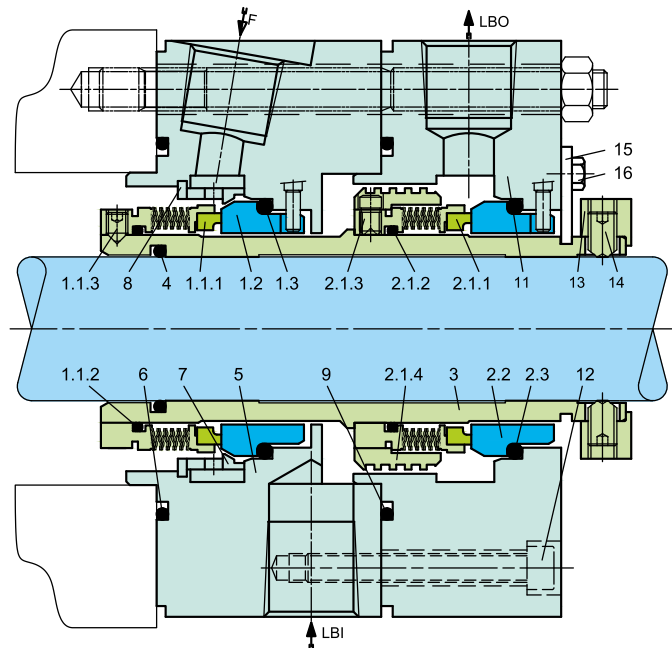

Item	Description
1.1.1, 2.1.1	Seal ring with Bellows Unit
1.1.2, 1.3, 2.1.2, 2.3, 4, 6, 9	O-ring
1.1.3, 2.1.3, 14	Set screw
2.1.4	Pumping sleeve
1.2, 2.2	Mating ring
3	Shaft sleeve
5	Gland
7	Multi-flow Distributor
8	Retaining ring
11	Cover
12	HSH cap screw
13	Set ring
15	Setting plate
16	Hexagon screw
F	Flush
LBI	Liquid Buffer/Barrier IN
LBO	Liquid Buffer/Barrier OUT

UFLWT800-Ta

API 682 4th Edition Category 2 & 3
 Seal type C (Rotating)
 Configuration 2CW-CW (Contacting Wet – Contacting Wet)
 Configuration 3CW-FB (Contacting Wet – Face-to-Back)

Product Description

1. API 682 Category 2 and 3, Type C, Arrangement 2 & 3 seal
2. Dual seal in face-to-back configuration
3. Balanced design
4. Independent of direction of rotation
5. Cartridge construction
6. For plain shafts
7. Rotary metal bellows design
8. Shrink fitted seal rings and solid mating rings

Technical Features

1. Suitable for high and low temperature application
2. Compact design
3. No dynamically loaded O-ring which reduces chances of seal face hang-up.
4. Pumping screw for media with higher viscosity also available
5. Short installation length possible
6. Rugged design for long operating life
7. Bellows design efficiently ensure self-cleaning
8. Bellows design minimizes variation in face load due to shaft expansion or face wear
9. Resistant to abrasive particles in the medium, no shaft or sleeve fretting

Typical Industrial Applications

- API 610/ISO 13709 pumps
- Chemical & Petrochemical industry
- Cold media
- Highly viscous media
- Hot media
- Power plant technology
- Refining technology
- Oil and gas industry
- Power plant technology
- LPG plants
- Process pumps

Performance Capabilities

Shaft diameter: $d_1 = 20 \dots 110 \text{ mm}$ (0.79" ... 4.33")
 Pressure: $p = \text{vacuum} \dots 20 \text{ bar}$ (290 PSI)
 Temperature: $t = -40 \text{ }^\circ\text{C} \dots +200 \text{ }^\circ\text{C}$ (-40 °F ... +392 °F)
 Sliding velocity: $vg \dots 23 \text{ m/s}$ (75 ft/s)

Materials

Seal rings: Blister resistant carbon
 Mating rings: Silicon carbide SSiC (Q1), RBSiC (Q2)
 Bellows: Hastelloy® C-276 (M5),
 option: Inconel® 718 (M6)
 Secondary seals: FKM (V), FFKM (K), EPDM (E), NBR (P)
 Metal parts: CrNiMo steel 316 (G), Hastelloy® C-276 (M5)

Recommended piping plans 2CW-CW

Process side:
 01, 02, 03, 11, 12, 13, 14, 21, 22, 23, 31, 32, 41
 Between seals: 52, 55
 Atmospheric side*: 61, 62, 65A, 65B
 * Throttle bushing on request

Recommended piping plans 3CW-FB

Process side:
 01, 02, 03, 11, 12, 13, 14, 21, 22, 23, 31, 32, 41
 Between seals: 53A, 53B, 53C, 54
 Atmospheric side*: 61, 62, 65A, 65B
 * Throttle bushing on request

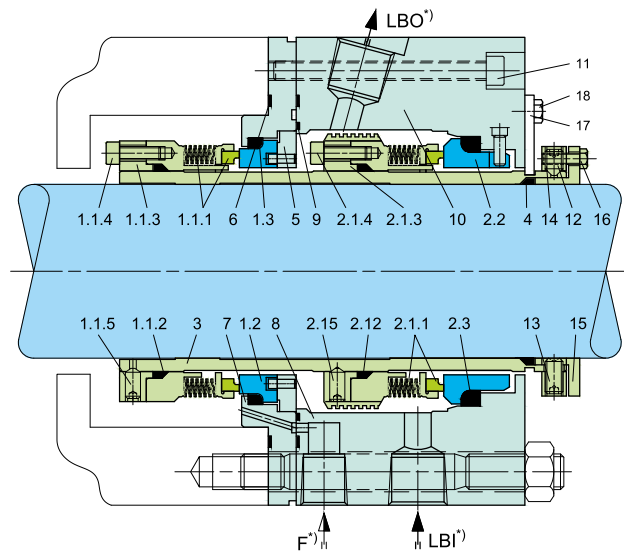

Item	Description
1.1.1, 2.1.1	Seal ring with Bellows Unit
1.1.2, 1.3, 2.1.2, 2.3, 4	Sealing ring
1.1.3	Thrust ring
1.1.4, 2.1.4, 11	HSH cap screw
1.1.5, 2.1.5, 13, 14	Set screw
1.2, 2.2	Mating ring
2.1.3	Thrust ring with pumping ring
3	Shaft sleeve
5	Adapter
6, 8, 9	Gasket
7	Intermediate gland
10	Gland
12	Set ring
15	Pusher ring
16, 18	Hexagon bolt
17	Setting plate
F	Flush
LBI	Liquid Buffer/Barrier IN
LBO	Liquid Buffer/Barrier OUT

UFL650-Ta

API 682 4th Edition Category 2 & 3
 Seal type C (Stationary)
 Configuration 2CW-CW (Contacting Wet – Contacting Wet)
 Configuration 3CW-FB (Contacting Wet – Face-to-Back)

Product Description

1. API 682 Category 2 and 3, Type C, Arrangement 2 & 3 seal
2. Dual seal in face-to-back configuration
3. Balanced design
4. Independent of direction of rotation
5. Cartridge construction
6. For plain shafts
7. Stationary metal bellows design
8. Shrink fitted seal rings and solid mating rings

Technical Features

1. Suitable for high and low temperature application
2. Compact design
3. No dynamically loaded O-ring which reduces chances of seal face hang-up.
4. Pumping screw for media with higher viscosity also available
5. Short installation length possible
6. Rugged design for long operating life
7. Bellows design efficiently ensure self-cleaning
8. Bellows design minimizes variation in face load due to shaft expansion or face wear
9. Resistant to abrasive particles in the medium, no shaft or sleeve fretting

Typical Industrial Applications

- Refining technology
- Oil and gas industry
- Petrochemical industry
- Chemical industry
- Power plant technology
- LPG plants
- API 610/ISO 13709 pumps
- Process pumps

Performance Capabilities

Shaft diameter: $d_1 = 20 \dots 110 \text{ mm}$ (0.79" ... 4.33")
 $p = \text{vacuum} \dots 20 \text{ bar}$ (... 290 PSI)
 Temperature: $t = -130 \text{ }^\circ\text{C} \dots +400 \text{ }^\circ\text{C}$ (-202 °F ... +752 °F)
 Sliding velocity: $v_g \dots 50 \text{ m/s}$ (... 164 ft/s)

Materials

Seal rings: Blister resistant carbon, Silicon carbide SSiC (Q1), RBSiC (Q2)
 Mating rings: Silicon carbide SSiC (Q1), RBSiC (Q2)
 Bellows: Inconel® 718 (M6)
 Secondary seals: Graphite (G)
 Metal parts: CrNiMo steel 316 (G), Carpenter® 42 (T4)

Recommended piping plans 2CW-CW

Process side:
 01, 02, 03, 11, 12, 13, 14, 21, 22, 23, 31, 32, 41
 Between seals: 52, 55
 Atmospheric side*: 61, 62, 65A, 65B
 * Throttle bushing on request

Recommended piping plans 3CW-FB

Process side:
 01, 02, 03, 11, 12, 13, 14, 21, 22, 23, 31, 32, 41
 Between seals: 53A, 53B, 53C, 54
 Atmospheric side*: 61, 62, 65A, 65B
 * Throttle bushing on request

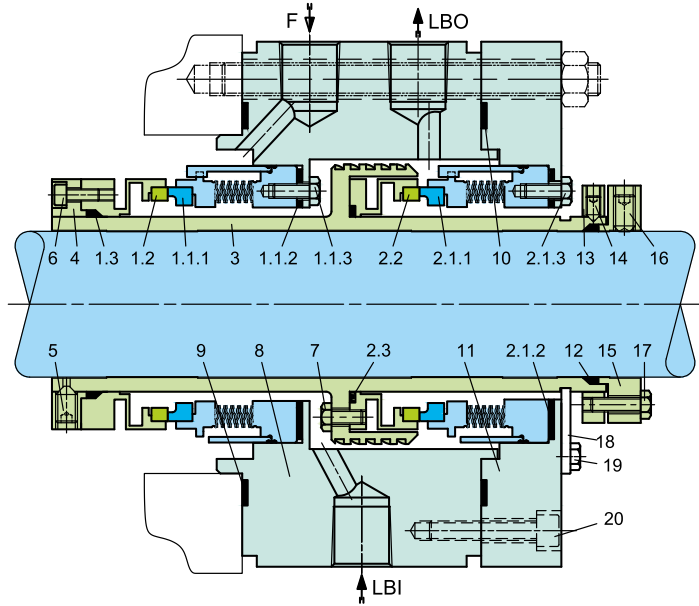

Item	Description
1.1.1, 2.1.1	Seal ring with Bellows Unit
1.1.2, 2.1.2, 2.3, 9, 10	Gasket
1.1.3, 2.1.3, 7, 17, 19	Hexagonal screw
1.2, 2.2	Mating ring
1.3, 12	Sealing ring
3	Shaft sleeve
4	Seat carrier
5, 14, 16	Set screw
6, 20	HSH cap screw
8	Intermediate gland
11	Gland
13	Set ring
15	Pusher ring
18	Setting Plate
F	Flush
LBI	Liquid Buffer/Barrier IN
LBO	Liquid Buffer/Barrier OUT

UFL850-D

API 682 4th Edition Category 2 & 3
 Seal type B (Rotating)
 Configuration 3CW-BB (Contacting Wet – Back-to-Back)

Product Description

1. API 682 Category 2 and 3, Type B, Arrangement 3 seal
2. Dual seal in back-to-back configuration
3. Balanced design
4. Independent of direction of rotation
5. Cartridge construction
6. For plain shafts
7. Rotary metal bellows design
8. Shrink fitted seal rings and solid mating rings

Technical Features

1. Suitable for high and low temperature application
2. Compact design
3. No dynamically loaded O-ring which reduces chances of seal face hang-up.
4. Pumping screw for media with higher viscosity also available
5. Short installation length possible
6. Rugged design for long operating life
7. Bellows design efficiently ensure self-cleaning
8. Bellows design minimizes variation in face load due to shaft expansion or face wear
9. Resistant to abrasive particles in the medium, no shaft or sleeve fretting

Typical Industrial Applications

- API 610/ISO 13709 pumps
- Chemical & Petrochemical industry
- Cold media
- Highly viscous media
- Hot media
- Power plant technology
- Refining technology
- Oil and gas industry
- Power plant technology
- LPG plants
- Process pumps

Performance Capabilities

Shaft diameter: $d_1 = 20 \dots 110 \text{ mm}$ (0.79" ... 4.33")
 Pressure: $p = \text{vacuum} \dots 20 \text{ bar}$ (290 PSI)
 Temperature: $t = -40 \text{ }^\circ\text{C} \dots +200 \text{ }^\circ\text{C}$ (-40 °F ... +392 °F)
 Sliding velocity: $v_g \dots 23 \text{ m/s}$ (75 ft/s)

Materials

Seal rings: Blister resistant carbon
 Mating rings: Silicon carbide SSiC (Q1), RBSiC (Q2)
 Bellows: Hastelloy® C-276 (M5),
 option: Inconel® 718 (M6)
 Secondary seals: FKM (V), FFKM (K), EPDM (E), NBR (P)
 Metal parts: CrNiMo steel 316 (G), Hastelloy® C-276 (M5)

Recommended piping plans

Process side:
 01, 02, 03, 11, 12, 13, 14, 21, 22, 31, 32, 41
 Between seals: 53A, 53B, 53C, 54
 Atmospheric side*: 61, 62, 65A, 65B
 * Throttle bushing on request

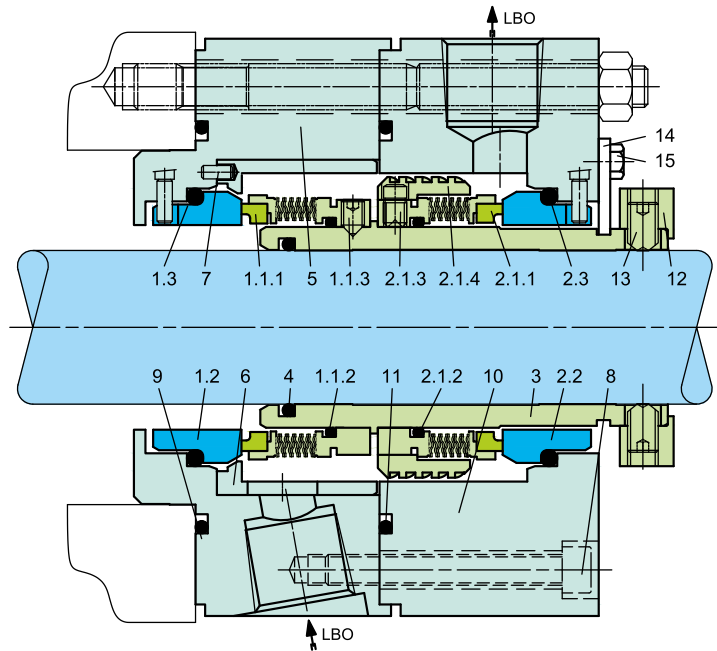

Item	Description
1.1.1, 2.1.1	Seal ring with Bellows Unit
1.1.2, 1.3, 2.1.2, 2.3, 4, 9, 11	O-ring
1.1.3, 2.1.3, 13	Set screw
1.2, 2.2	Mating ring
2.1.4	Pumping ring
3	Shaft sleeve
5	Gland
6	Adapter Sleeve
7	Pin
8	HSH cap screw
10	Intermediate Gland
12	Set ring
14	Assembly plate
15	Hexagonal bolt
LBI	Liquid Barrier IN
LBO	Liquid Barrier OUT

UFLWT800-D

API 682 4th Edition Category 2 & 3
Seal type C (Rotating)
Configuration 3CW-BB (Contacting Wet – Back-to-Back)

Product Description

1. API 682 Category 2 and 3, Type C, Arrangement 3 seal
2. Dual seal in back-to-back configuration
3. Balanced design
4. Independent of direction of rotation
5. Cartridge construction
6. For plain shafts
7. Rotary metal bellows design
8. Shrink fitted seal rings and solid mating rings

Technical Features

1. Suitable for high and low temperature application
2. Compact design
3. No dynamically loaded O-ring which reduces chances of seal face hang-up.
4. Pumping screw for media with higher viscosity also available
5. Short installation length possible
6. Rugged design for long operating life
7. Bellows design efficiently ensure self-cleaning
8. Bellows design minimizes variation in face load due to shaft expansion or face wear
9. Resistant to abrasive particles in the medium, no shaft or sleeve fretting

Typical Industrial Applications

- API 610/ISO 13709 pumps
- Chemical & Petrochemical industry
- Cold media
- Highly viscous media
- Hot media
- Power plant technology
- Refining technology
- Oil and gas industry
- Power plant technology
- LPG plants
- Process pumps

Performance Capabilities

Shaft diameter: $d_1 = 20 \dots 110 \text{ mm}$ (0.79" ... 4.33")
 $p = \text{vacuum} \dots 25 \text{ bar}$ (... 363 PSI)
 Temperature: $t = -75 \text{ }^\circ\text{C} \dots +400 \text{ }^\circ\text{C}$ (-103 °F ... +752 °F)
 Sliding velocity: $v_g \dots 23 \text{ m/s}$ (... 75 ft/s)

Materials

Seal rings: Blister resistant carbon, Silicon carbide SSiC (Q1), RBSiC (Q2)
 Mating rings: Silicon carbide SSiC (Q1), RBSiC (Q2)
 Bellows: Inconel® 718 (M6)
 Secondary seals: Graphite (G)
 Metal parts: CrNiMo steel 316 (G), Carpenter® 42 (T4)

Recommended piping plans

Process side:
 01, 02, 03, 11, 12, 13, 14, 21, 22, 31, 32, 41
 Between seals: 53A, 53B, 53C, 54
 Atmospheric side*: 61, 62, 65A, 65B
 * Throttle bushing on request

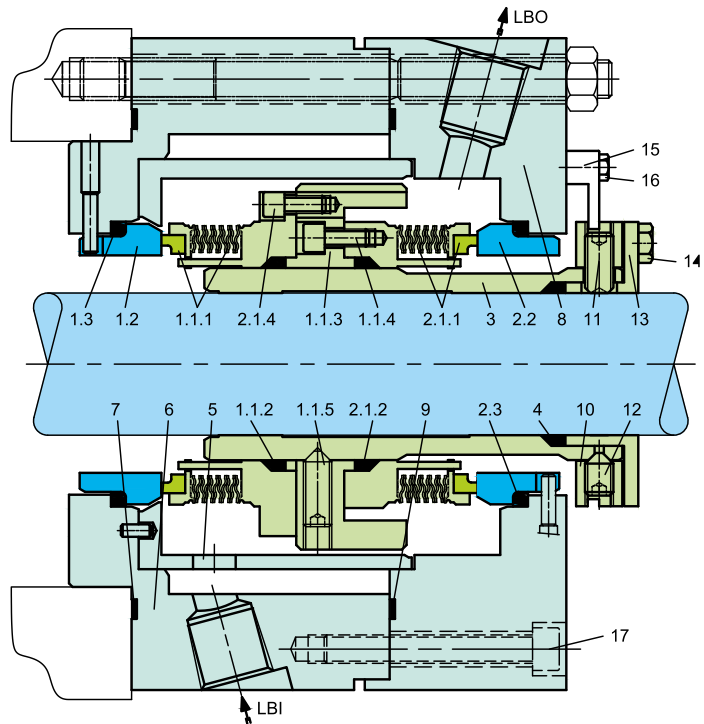

Item	Description
1.1.1, 2.1.1	Seal ring with Bellows Unit
1.1.2, 2.1.2, 1.3, 2.3, 4	Sealing ring
1.1.3	Drive collar with pumping ring
1.1.4, 2.1.4, 17	HSH cap screw
1.1.5, 11, 12	Set screw
1.2, 2.2	Mating ring
3	Shaft sleeve
5	Adapter
6	Intermediate gland
7, 9	Gasket
8	Gland
10	Set ring
13	Pusher ring
14, 16	Hexagon screw
15	Assembly plate
LBI	Liquid Barrier IN
LBO	Liquid Barrier OUT

UFL650-D

API 682 4th Edition Category 2 & 3
 Seal type C (Stationary)
 Configuration 3CW-FF (Contacting Wet – Face-to-Face)

Product Description

1. API 682 Category 2 and 3, Type C, Arrangement 3 seal
2. Dual seal in face-to-face configuration
3. Balanced design
4. Independent of direction of rotation
5. Cartridge construction
6. For plain shafts
7. Stationary metal bellows design
8. Shrink fitted seal rings and solid mating rings

Technical Features

1. Suitable for high and low temperature application
2. Compact design
3. No dynamically loaded O-ring which reduces chances of seal face hang-up.
4. Pumping screw for media with higher viscosity also available
5. Short installation length possible
6. Rugged design for long operating life
7. Bellows design efficiently ensure self-cleaning
8. Bellows design minimizes variation in face load due to shaft expansion or face wear
9. Resistant to abrasive particles in the medium, no shaft or sleeve fretting

Typical Industrial Applications

- Refining technology
- Oil and gas industry
- Petrochemical industry
- Chemical industry
- Power plant technology
- LPG plants
- API 610/ISO 13709 pumps
- Process pumps

Performance Capabilities

Shaft diameter: $d_1 = 20 \dots 110 \text{ mm}$ (0.79" ... 4.33")
 $p = \text{vacuum} \dots 20 \text{ bar}$ (... 290 PSI)
 Temperature: $t = -130 \text{ }^\circ\text{C} \dots +400 \text{ }^\circ\text{C}$ (-202 °F ... +752 °F)
 Sliding velocity: $v_g \dots 50 \text{ m/s}$ (... 164 ft/s)

Materials

Seal rings: Blister resistant carbon, Silicon carbide SSiC (Q1), RBSiC (Q2)
 Mating rings: Silicon carbide SSiC (Q1), RBSiC (Q2)
 Bellows: Inconel® 718 (M6)
 Secondary seals: Graphite (G)
 Metal parts: CrNiMo steel 316 (G), Carpenter® 42 (T4)

Recommended piping plans

Process side: 01, 02, 03, 11, 12, 13, 14, 21, 22, 31, 32, 41
 Between seals: 53A, 53B, 53C, 54
 Atmospheric side*: 61, 62, 65A, 65B
 * Throttle bushing on request

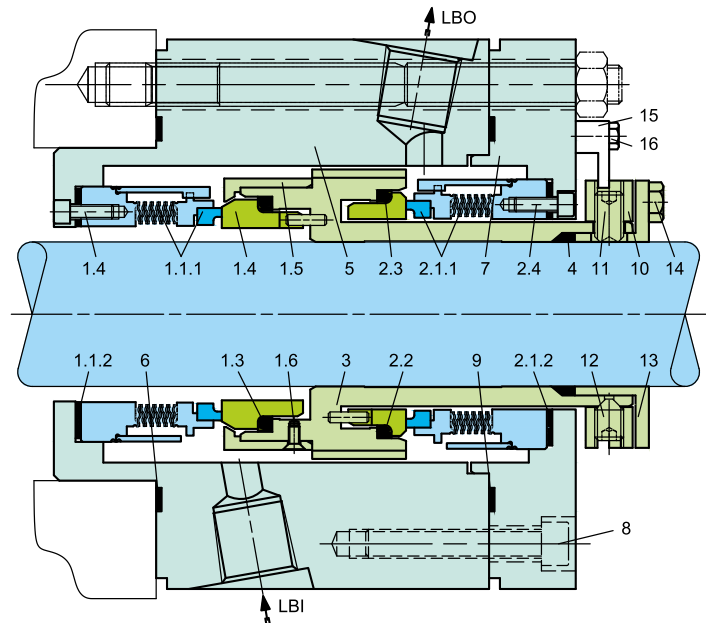

Item	Description
1.1.1, 2.1.1	Seal ring with Bellows unit
1.1.2, 2.1.2, 6, 9	Gasket
1.2, 2.2	Mating ring
1.3, 2.3, 4	Sealing ring
1.4, 2.4, 8	HSH cap screw
1.5	Lock ring
1.6, 11, 12	Set screw
3	Shaft sleeve
5	Intermediate gland
7	Gland
10	Set ring
13	Pusher ring
14, 16	Hexagon bolt
15	Assembly plate
LBI	Liquid Barrier IN
LBO	Liquid Barrier OUT

B750VK-GSPH

API 682 4th Edition Category 2 & 3
Seal Type A (Rotating)
Configuration 2CW-CS (Contacting Wet – Containment Seal)

Product Description

1. API 682 Category 2 and 3, Type A, Arrangement 2 seal
2. Dual seal in face-to-back configuration
3. Balanced design
4. Non contact outer seal (containment seal)
5. Cartridge construction
6. Rotating unit with multiple springs

Technical Features

1. Suitable for both, retrofits and original equipment
2. Varied selection of materials available
3. Safe operation due to metal torque transmission at the rotating carbon seal rings

Typical Industrial Applications

- API 610/ISO 13709 pumps
- Media with gaseous leakage
- Oil and gas industry
- Petrochemical industry
- Refining technology
- Process pumps

Performance Capabilities

Shaft diameter: $d = 20 \dots 110 \text{ mm}$ (0.79" ... 4.33")
 Pressure: $p_1 = 42 \text{ bar}$ (609 PSI)
 Temperature: $t = -40 \text{ °C} \dots +176 \text{ °C}$ (-40 °F ... +350 °F)
 Sliding velocity: $v_g = 23 \text{ m/s}$ (76 ft/s)
 Axial movement: $\pm 1.0 \text{ mm}$

Materials

Seal rings: Blister resistant carbon, Silicon carbide SSiC (Q1), RBSiC (Q2)
 Mating rings: Silicon carbide SSiC (Q1), RBSiC (Q2)
 Secondary seals: EPDM (E), NBR (P), FKM (V), FFKM (K)
 Springs: Hastelloy® C-276 (M5)
 Metal parts: CrNiMo steel 316 (G) or equivalent, optional materials on request.

Recommended piping plans

Process side:
 01, 02, 03, 11, 12, 13, 14, 21, 22, 23, 31, 32, 41
 Between seals: 71, 72, 75, 76

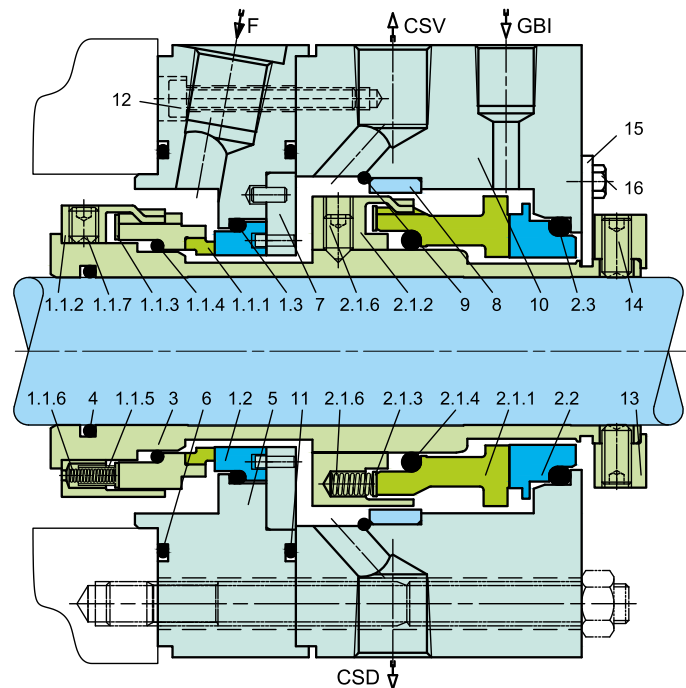

Item	Description
1.1.1, 2.1.1	Seal ring
1.1.2, 2.1.2	Driver
1.1.3, 2.1.3	Thrust ring
1.1.4, 1.3, 2.1.4, 2.3, 4, 6, 11	O-ring
1.1.5,	Spring sleeve
1.1.6, 2.1.5	Spring
1.1.7, 2.1.6, 14	Set screw
1.2, 2.2	Mating ring
3	Shaft sleeve
5	Intermediate gland
7	Washer
8	Throttle bush
9	Retaining ring
10	Cover
12	HSH cap screw
13	Set ring
15	Assembly plate
16	Hexagon bolt
F	Flush
GBI	Gas Buffer IN
CSV	Containment Seal Vent
CSD	Containment Seal Drain

GSPH-Ta

API 682 4th Edition Category 1, 2 & 3
 Seal type A (Rotating)
 Configuration 2NC-CS (Non Contacting – Containment Seal)

Product Description

1. API 682 Category 1, 2 and 3, Type A, Arrangement 2 seal
2. Dual seal in face-to-back configuration
3. Gas-lubricated
4. Independent of direction of rotation (with U-grooves)
5. Cartridge construction
6. Contact free operation, no friction
7. Rotary multiple springs

Technical Features

1. Suitable for both, retrofits and original equipment
2. Varied selection of materials available
3. Designed for vaporizing media
4. Operation close to vapor pressure

Typical Industrial Applications

- Refining technology
- Petrochemical industry
- Chemical industry
- Oil and gas industry
- Media with gaseous leakage
- API 610/ISO 13709 pumps
- Process pumps

Performance Capabilities

Shaft diameter: $d_1 = 20 \dots 110 \text{ mm}$ (0.79" ... 4.33")
 Pressure: $p_1 = 20 \text{ bar}$ (290 PSI)
 Temperature: $t = -40 \text{ }^\circ\text{C} \dots +176 \text{ }^\circ\text{C}$ (-40 °F ... +350 °F)
 Sliding velocity: $v_g = 4 \dots 23 \text{ m/s}$ (13 ... 76 ft/s)
 Axial movement: $\pm 1.0 \text{ mm}$

Materials

Seal rings: Blister resistant carbon, Silicon carbide SSiC (Q1), RBSiC (Q2)
 Mating rings: Silicon carbide SSiC (Q1), RBSiC (Q2)
 Secondary seals: EPDM (E), NBR (P), FKM (V), FFKM (K)
 Springs: Hastelloy® C-4 (M)* and C-276 (M5)
 Metal parts: CrNiMo steel 316 (G) or equivalent, optional materials on request.
 * Sealmatic standard

Recommended piping plans

Process side: 02, 03
 Between seals: 71, 72, 76

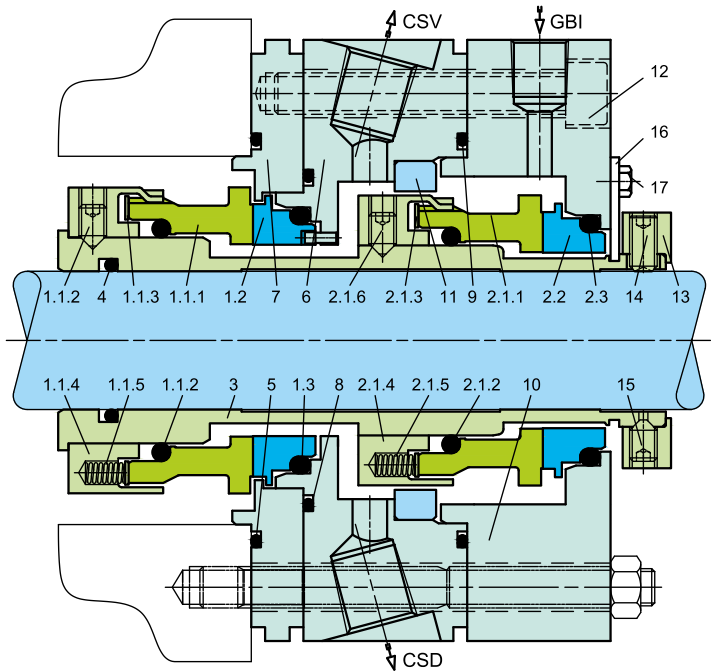

Item	Description
1.1.1, 2.1.1	Seal ring
1.1.2, 1.3, 2.1.2, 2.3, 4, 5, 8, 9	O-ring
1.1.3, 2.1.3	Thrust ring
1.1.4, 2.1.4	Driver
1.1.5, 2.1.5	Spring
1.1.6, 2.1.6, 14, 15	Set screw
1.2, 2.2	Mating ring
3	Shaft sleeve
6	Intermediate gland
7	Gland
10	Cover
11	Throttle bush
12	HSH cap screw
13	Set ring
16	Assembly plate
17	Hexagon bolt
CSV	Containment Seal Vent
CSD	Containment Seal Drain
GBI	Gas Buffer IN

GSPH-KD

API 682 4th Edition Category 1, 2 & 3
 Seal type A (Rotating)
 Configuration 3NC-BB (Non Contacting – Back-to-Back)

Product Description

1. API 682 Category 1, 2 and 3, Type A, Arrangement 3 seal
2. Dual seal in back-to-back configuration
3. Gas-lubricated
4. Independent of direction of rotation (with U-grooves)
5. Cartridge construction
6. Contact free operation, no friction
7. Rotary multiple springs

Technical Features

1. Suitable for both, retrofits and original equipment
2. Varied selection of materials available
3. Safe operation due to metal torque transmission at the rotating carbon seal rings

Typical Industrial Applications

- API 610/ISO 13709 pumps
- Media with gaseous leakage
- Oil and gas industry
- Petrochemical industry
- Refining technology
- Process pumps

Performance Capabilities

Shaft diameter: $d = 20 \dots 110 \text{ mm}$ (0.79" ... 4.33")
 Pressure: $p_1 = 23 \text{ bar}$ (333 PSI)
 Temperature: $t = -20 \dots +176 \text{ }^\circ\text{C}$ (-4°F ... +350°F)
 Sliding velocity: $vg = 23 \text{ m/s}$ (76 ft/s)
 Axial movement: $\pm 1.0 \text{ mm}$

Materials

Seal rings: Blister resistant carbon, Silicon carbide SSiC (Q1)
 Mating rings: Silicon carbide SSiC (Q1), RBSiC (Q2)
 Secondary seals: EPDM (E), NBR (P), FKM (V), FFKM (K)
 Springs: Hastelloy® C-4 (M)* and C-276 (M5)
 Metal parts: CrNiMo steel 316 (G) or equivalent, optional materials on request.
 * Sealmatic standard

Recommended piping plans

Process side*: 01, 02, 03, 11, 12, 21, 22, 31, 32, 41
 Between seals: 74
 * Piping plans 11 ... 41:
 Integration in seal to be dimensionally checked.

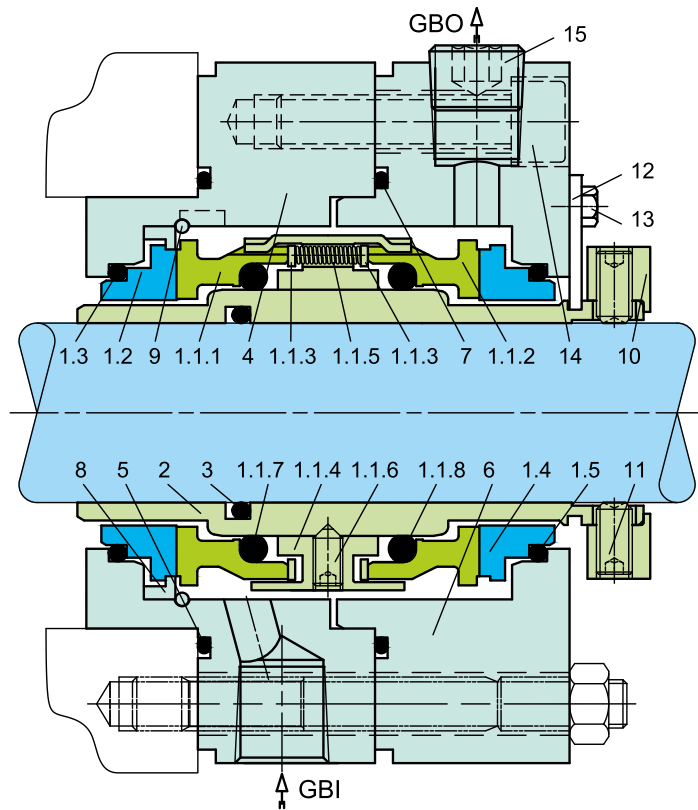

Item	Description
1.1.1, 1.1.2	Seal ring
1.1.3	Thrust ring
1.1.4	Driver
1.1.5	Spring
1.1.6, 11	Set screw
1.1.7, 1.1.8, 1.3, 1.5, 3, 5, 7	O-ring
1.2, 1.4	Mating ring
2	Shaft sleeve
4	Intermediate gland
6	Gland
8	Washer
9	Retaining ring
10	Set ring
12	Assembly Plate
13	Hexagonal screw
14	HSH cap screw
15	Plug
GBI	Gas Barrier IN
GBO	Gas Barrier OUT

BGSR-Ta

API 682 4th Edition Category 2/3
 Seal type A (Stationary)
 Configuration 3NC-FB (Non Contacting – Face-to-Back)

Product Description

1. API 682 Category 2 and 3, Type A, Arrangement 3 seal
2. Dual seal in face-to-back configuration
3. Gas-lubricated
4. Cartridge construction
5. Balanced design
6. Independent of direction of rotation
7. Contact free operation, no friction
8. Stationary springs

Technical Features

1. Suitable for both, retrofits and original equipment
2. Varied selection of materials available
3. Metal parts available in special materials

Typical Industrial Applications

- API 610/ISO 13709 pumps
- Media with gaseous leakage
- Oil and gas industry
- Petrochemical industry
- Refining technology
- Process pumps
- Media which require high purity
- Environmentally harmful media

Performance Capabilities

Shaft diameter: $d = 20 \dots 110 \text{ mm}$ (0.79" ... 4.33")
 Pressure : $p_1 = 42 \text{ bar}$ (609 PSI)
 Temperature: $t = -20 \text{ }^\circ\text{C} \dots +176 \text{ }^\circ\text{C}$ (-4 °F ... +350 °F)
 Sliding velocity: $v_g = 4 \dots 23 \text{ m/s}$ (13 ... 76 ft/s)
 Axial movement: $\pm 1.0 \text{ mm}$

Materials

Seal ring (product side): Silicon carbide Q19, SSiC (Q1)
 Seal ring (atmospheric side): Blister resistant carbon, Silicon carbide SSiC (Q1), Q19
 Mating rings: Silicon carbide SSiC (Q1), RBSiC (Q2)
 Secondary seals: EPDM (E), NBR (P), FKM (V), FFKM (K)
 Springs: Hastelloy® C-4 (M)* and C-276 (M5)
 Metal parts: CrNiMo steel 316 (G) or equivalent, optional materials on request.
 * Sealmatic standard

Recommended piping plans

Process side: 01, 02, 03, 11, 12, 21, 22, 31, 32, 41
 Between seals: 74

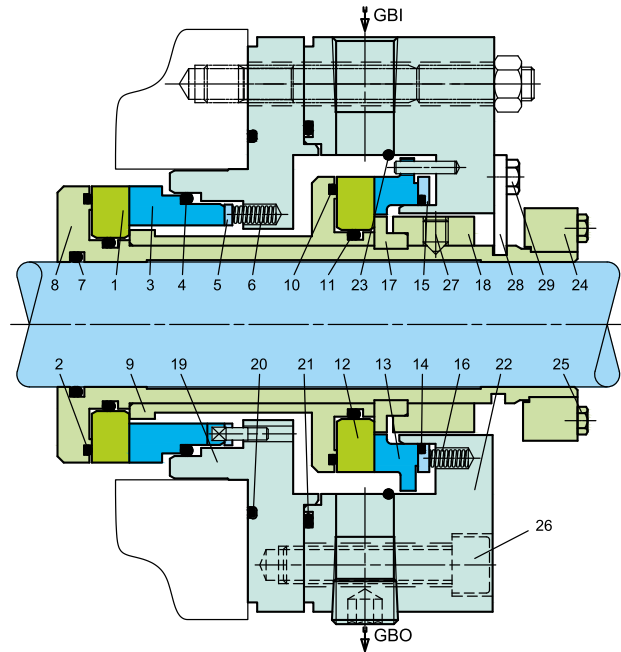

Item	Description
1, 12	Seal ring
2, 4, 7, 10, 11, 14, 20, 21	O-ring
3, 13	Mating ring
5, 15	Thrust ring
6, 16	Spring
8	Shaft sleeve
9	Adapter sleeve
17	Support ring
18	Pusher ring
19	Intermediate gland
22	Gland
23	Retaining ring
24	Set ring
25, 29	Hexagonal bolt
26	HSH cap screw
27	Set screw
28	Assembly plate
GBI	Gas Barrier IN
GBO	Gas Barrier OUT

GSR-D

API 682 4th Edition Category 2/3
 Seal type A (Stationary)
 Configuration 3NC-FF (Non Contacting – Face-to-Face)

Product Description

1. API 682 Category 2 and 3, Type A, Arrangement 3 seal
2. Dual seal in face-to-face configuration
3. Gas-lubricated
4. Cartridge construction
5. Balanced design
6. Independent of direction of rotation
7. Contact free operation, no friction
8. Stationary spring on process and atmospheric side

Technical Features

1. Suitable for both, retrofits and original equipment
2. Varied selection of materials available
3. Metal parts available in special materials

Typical Industrial Applications

- API 610/ISO 13709 pumps
- Media with gaseous leakage
- Oil and gas industry
- Petrochemical industry
- Refining technology
- Process pumps
- Media which require high purity
- Environmentally harmful media

Performance Capabilities

Shaft diameter: $d = 20 \dots 110 \text{ mm}$ (0.79" ... 4.33")
 Pressure: $p_1 = 42 \text{ bar}$ (609 PSI)
 Temperature: $t = -20 \text{ }^\circ\text{C} \dots +176 \text{ }^\circ\text{C}$ (-4 °F ... +350 °F)
 Sliding velocity: $v_g = 4 \dots 23 \text{ m/s}$ (13 ... 76 ft/s)
 Axial movement: $\pm 1.0 \text{ mm}$

Materials

Seal rings: Blister resistant carbon, Silicon carbide Q19
 Mating rings: Silicon carbide SSiC (Q1), RBSiC (Q2)
 Secondary seals: EPDM (E), NBR (P), FKM (V), FFKM (K)
 Springs: Hastelloy® C-4 (M)* and C-276 (M5)
 Metal parts: CrNiMo steel 316 (G) or equivalent, optional materials on request.
 * Sealmatic standard

Recommended piping plans

Process side*: 01, 02, 03, 11, 12, 21, 22, 31, 32, 41
 Between seals: 74
 * Piping plans 11 ... 41:
 Integration in seal to be dimensionally checked.

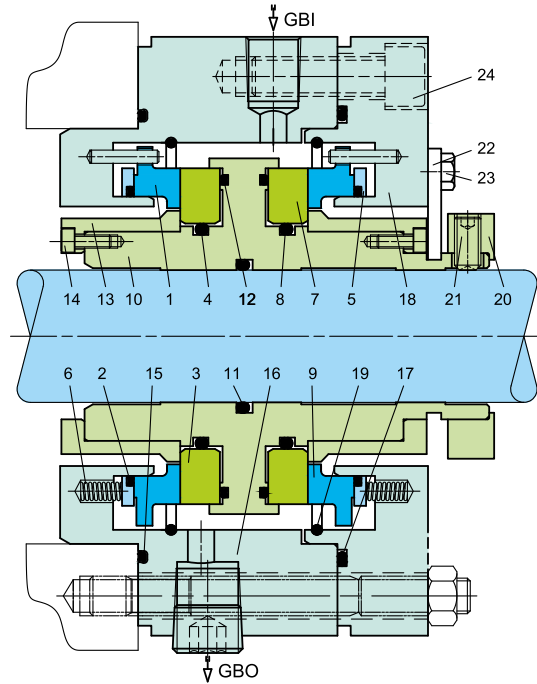

Item	Description
1,9	Seal ring
2, 4, 8, 11, 12, 15 17	O-ring
3, 7	Mating ring
5	Thrust ring
6	Spring
10	Shaft sleeve
13	Support ring
14, 23	Hexagonal bolt
16	Intermediate gland
18	Gland
19	Retaining ring
20	Set ring
21	Set screw
22	Assembly plate
GBI	Gas Barrier IN
GBO	Gas Barrier OUT

API Piping Plans – Process Side

Instrument symbols		Equipment symbols	
FO	Flow orifice	Bladder accumulator	Valve, normally open
LI	Level indicator	Cyclone separator	Valve, normally closed
LIT	Level transmitter with local indicator	Filter, coalescing	Valve, check
PDIT	Differential pressure transmitter with local indicator	Flow orifice	Valve, needle
PI	Pressure indicator	Seal cooler	Valve, pressure control
PIT	Pressure transmitter with local indicator	Strainer, Y	Valve, pressure relief
TI	Temperature indicator		
TIT	Temperature transmitter with local indicator		
HLA	High level alarm set point		
LLA	Low level alarm set point		
NLL	Normal liquid level		

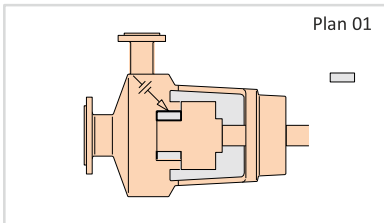

Integral (internal) recirculation from the pump discharge to seal chamber

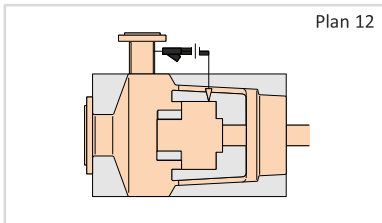

Recirculation from the pump discharge through a strainer and a flow control orifice into the seal chamber.

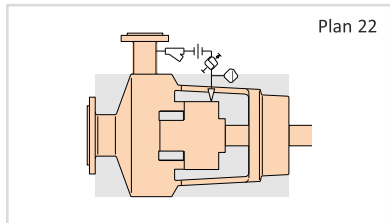

Recirculation from the pump discharge through a strainer and a flow control orifice and a cooler into the seal chamber.

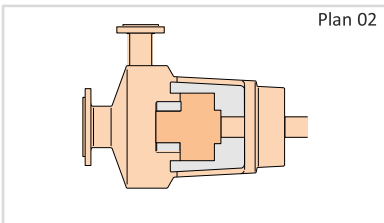

Dead-ended seal chamber with no recirculation of flushed fluid. Flush connections plugged.

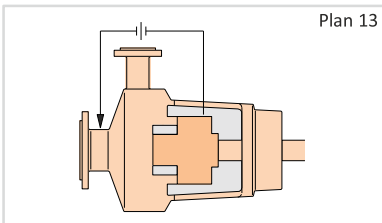

Recirculation from the seal chamber through a flow control orifice and back to the pump suction or pump suction piping.

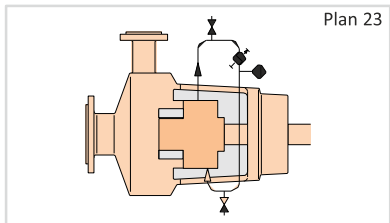

Recirculation from a circulation device in the seal chamber through a cooler and back into the seal chamber.

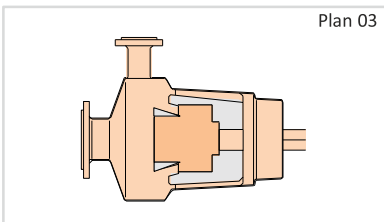

Circulation between the seal chamber and the pump created by the design of the seal chamber. Flush connections plugged.

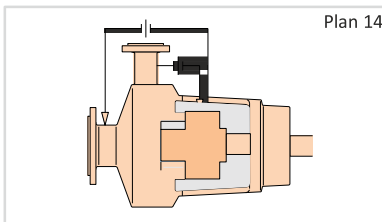

Recirculation from pump discharge through a flow control orifice to the seal and simultaneously from the seal chamber through a flow control orifice to pump suction.

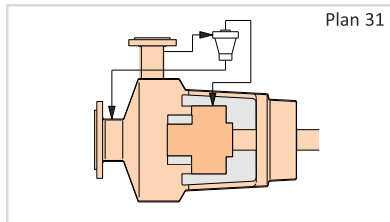

Recirculation from the pump discharge through a cyclone separator delivering the clean fluid to the seal chamber. The solids are delivered to the pump suction line.

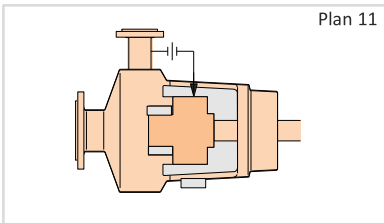

Recirculation from the pump discharge through a flow control orifice into the seal chamber.

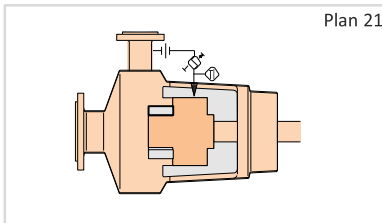

Recirculation from pump discharge through a flow control orifice and cooler into the seal chamber.

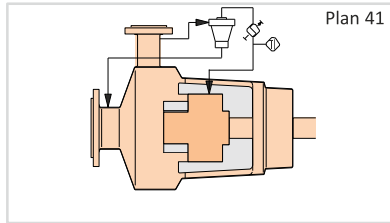

Recirculation from the pump discharge through a cyclone separator delivering the clean fluid to a cooler and then to the seal chamber. The solids are delivered to the pump suction line.

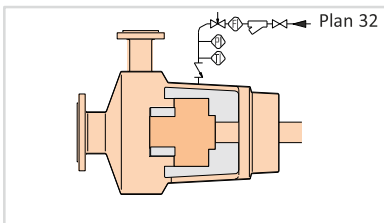

Injection of clean fluid into the seal chamber from an external source.

API Piping Plans – Between Seals

Instrument symbols		Equipment symbols	
(FO) Flow orifice	(TI) Temperature indicator	Bladder accumulator	Valve, normally open
(LI) Level indicator	(TTI) Temperature transmitter with local indicator	Cyclone separator	Valve, normally closed
(LIT) Level transmitter with local indicator	HLA High level alarm set point	Filter, coalescing	Valve, check
(PDI) Differential pressure transmitter with local indicator	LLA Low level alarm set point	Flow orifice	Valve, needle
(PI) Pressure indicator	NLL Normal liquid level	Seal cooler	Valve, pressure control
(PIT) Pressure transmitter with local indicator		Strainer, Y	Valve, pressure relief

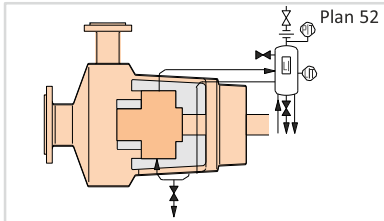

Reservoir providing buffer liquid for the outer seal of an arrangement 2 unpressurized dual seal. The buffer liquid

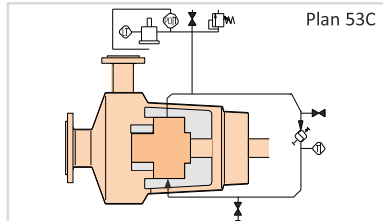

Recirculation from pump discharge through a flow control orifice and cooler into the seal chamber.

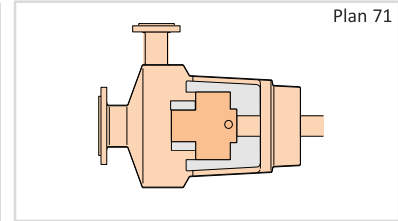

Tapped connections for the purchaser's use, e.g., for future use of buffer gas.

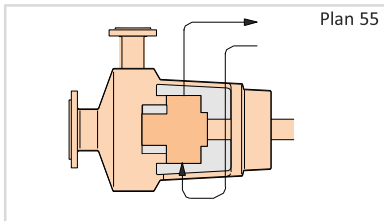

Unpressurized external buffer fluid system supplying clean buffer liquid for the outer seal of an arrangement 2 unpressurized dual seal. Buffer liquid is supplied by an external pump or pressure system.

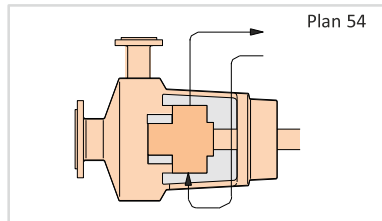

Pressurized external barrier fluid system supplying clean liquid for an arrangement 3 pressurized dual seal. The barrier liquid is maintained at a pressure greater than seal chamber pressure and is circulated by an external pump or pressure system.

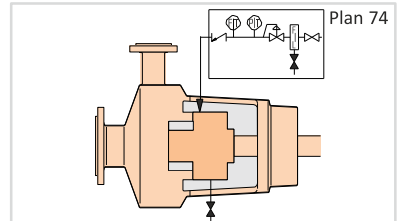

Externally supplied barrier gas for arrangement 3 dual pressurized non-contacting gas seals (3NC-FB, 3NCBB, 3NC-FF).

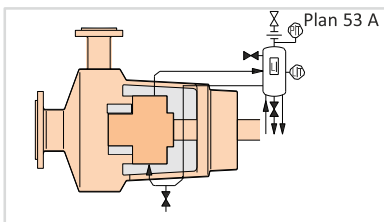

Pressurized barrier fluid reservoir supplying clean fluid for an arrangement 3 pressurized dual seal.

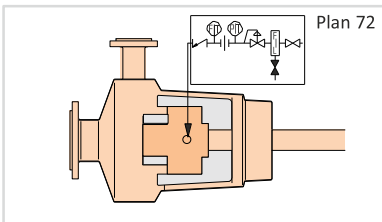

Externally supplied buffer gas for arrangement 2 unpressurized seals with dry running containment seal (2CW-CS and 2NC-CS). Buffer gas is maintained at a pressure less than seal chamber pressure. The buffer gas pressure should not exceed 0.7 bar (10 PSI)

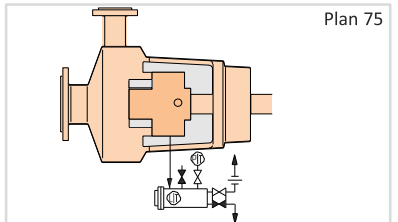

A containment seal chamber leakage collection system for condensing or mixed phase leakage on arrangement 2 unpressurized seals with containment seals (2CW-CS and 2NC-CS).

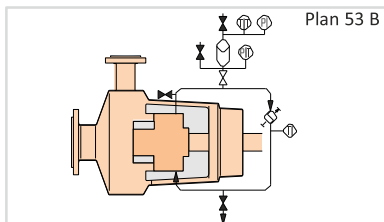

Barrier fluid system pressurized by a bladder accumulator supplying clean liquid for an arrangement 3 pressurized dual seal.

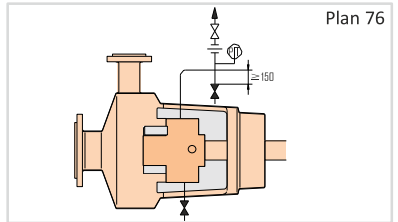

A containment seal chamber drain for non-condensing leakage on arrangement 2 unpressurized seals with containment seals (2CW-CS and 2NC-CS). Used if the pumped fluid does not condense at ambient temperatures.

API Piping Plans – Atmospheric Side

Instrument symbols		Equipment symbols	
FO	Flow orifice	TI	Temperature indicator
LI	Level indicator	TIIT	Temperature transmitter with local indicator
LIT	Level transmitter with local indicator	HLA	High level alarm set point
PDIIT	Differential pressure transmitter with local indicator	LLA	Low level alarm set point
PI	Pressure indicator	NLL	Normal liquid level
PIIT	Pressure transmitter with local indicator		Bladder accumulator
			Cyclone separator
			Filter, coalescing
			Flow orifice
			Seal cooler
			Strainer, Y
			Valve, normally open
			Valve, normally closed
			Valve, check
			Valve, needle
			Valve, pressure control
			Valve, pressure relief

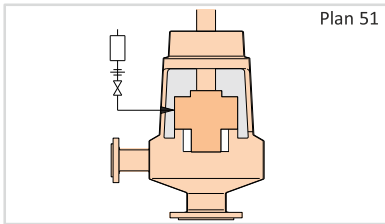

Plan 51

Reservoir providing a dead-ended blanket for fluid to the quench connection of the gland plate. Only recommended for vertical pumps.

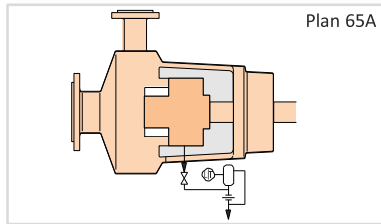

Plan 65A

Atmospheric leakage collection and alarm system for condensing leakage. Failure of the seal will be detected by an excessive flow rate into the leakage collection system.

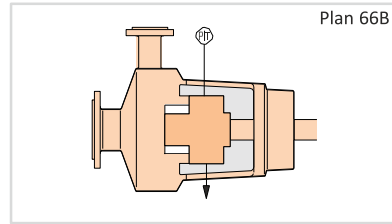

Plan 66B

An orifice plug in the drain port minimizes the seal leakage leaving the seal gland and allows for detection of a seal failure by an alarm of the monitoring pressure transmitter.

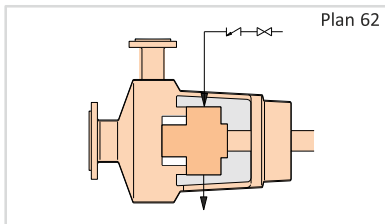

Plan 62

Quench stream from an external source to the atmospheric side of the seal faces. The quench stream can be low pressure steam, nitrogen or clean water.

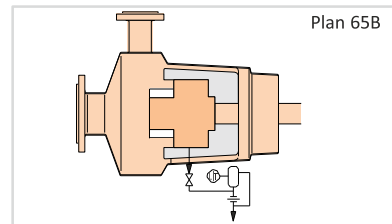

Plan 65B

Atmospheric leakage collection and detection system for condensing leakage. Failure of the seal will be detected by a cumulative leakage into the system.

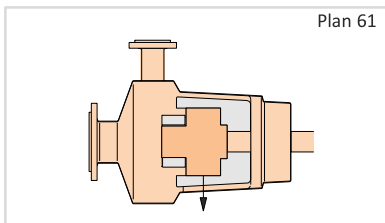

Plan 61

Tapped and plugged atmospheric-side connections for purchaser's use.

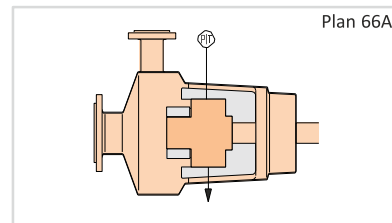

Plan 66A

Throttle bushings in the seal gland minimize the seal leakage leaving the seal gland and allow for detection of a seal failure by an alarm of the monitoring pressure transmitter.

API Piping Plans - Engineered

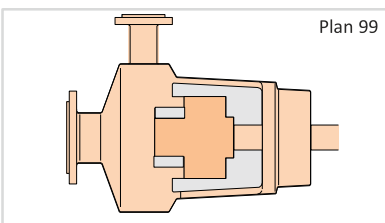

Plan 99

Engineered piping plan not defined by other existing plans.

Certificate of Registration

The American Petroleum Institute certifies that the quality management system of

SEALMATIC INDIA LIMITED
Unit No. 'A', Indiplex-IV, Survey No. 12/9-A,
Shanti Vidya Nagari Road, Ghodbunder Village, Mira Road (East)
Thane/Mira Bhaynder, Maharashtra
India

has been assessed by the American Petroleum Institute and found to be in conformance with the following:

API Spec Q1, 10th Edition

The scope of this registration and the approved quality management system applies to the
**Design, Manufacture, Supply and Service of
Mechanical Seals as per API Standard 682**

API approves the organization's justification for excluding
No Exclusions Identified as Applicable



Effective Date: APRIL 3, 2026
Expiration Date: APRIL 3, 2029
Registered Since: APRIL 3, 2020

Anchal Liddar

Senior Vice President of Global Industry Services

This certificate is valid for the period specified herein. The registered organization must continually meet all requirements of API Spec Q1, *Specification for Quality Management System Requirements for Manufacturing Organizations for the Petroleum and Natural Gas Industry*, and the requirements of the Registration Agreement. Registration is maintained and regularly monitored through annual full system audits. This certificate has been issued from API offices located at 200 Massachusetts Avenue, NW Suite 1100, Washington, DC 20001-5571, U.S.A. It is the property of API and must be returned upon request.
To verify the authenticity of this certificate, go to www.api.org/compositelist.

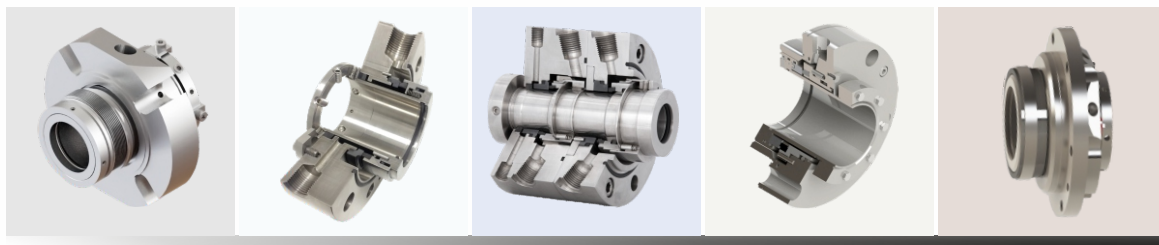

API 682 4TH EDITION

Mechanical Seals For

Oil & Gas, Refinery, Petrochemical, Fertiliser, Chemical &
Many More Applications



Bldg A, Indiplex IV, Village Ghodbunder, Shanti Vidya Nagri Road, Mira Road (E), Thane - 401107, India.
Tel.: +91 22 5050 2700 Email : info@sealmaticindia.com Website : www.sealmaticindia.com

sealmaticindia.com

